



KARL DEUTSCH

Automated Ultrasonic Pipe Weld Inspection

Dr. (USA) Dipl.-Ing. Wolfram A. Karl Deutsch, Dipl.-Ing. Peter Schulte, Dipl.-Ing. Michael Joswig, Dipl.-Ing. Rainer Kattwinkel

KARL DEUTSCH Instruments, Sensors & Systems for NDT, Wuppertal Germany, www.karldeutsch.de

Summary

This article contains a brief overview on automated ultrasonic weld inspection for various pipe types. Some inspection steps might be carried out with portable test equipment (e.g. pipe end test), but the weld inspection in all internationally relevant specification must be automated. The pipe geometry, the production process, and the pipe usage determine the number of required probes. Recent updates for some test specifications enforce a large number of ultrasonic probes, e.g. the SHELL standard. Since seamless pipes are sometimes replaced by ERW pipes and LSAW pipes by SSAW pipes (in both cases to save production cost), the inspection methods change gradually between the various pipe types. Each testing system is unique and shows its specialties which have to be discussed by supplier, testing system user and final customer of the pipe.

The presentation during the upcoming WCNDT in Shanghai will focus on three ultrasonic testing systems which were shipped to BAOSTEEL in 2007 and which are currently under installation. Two weld testing systems for large diameter pipes with longitudinal submerged arc weld and one pipe-end testing system enable the pipe mill to inspect their products with high throughput. Testing speeds for the pipe weld of up to 1 m/s are feasible due to the specific system design and the respective pipe transportation devices.

Automated Ultrasonic Pipe Weld Inspection

Dr. (USA) Dipl.-Ing. Wolfram A. Karl Deutsch, Dipl.-Ing. Peter Schulte, Dipl.-Ing. Michael Joswig, Dipl.-Ing. Rainer Kattwinkel,

KARL DEUTSCH Instruments, Sensors & Systems for NDT, Wuppertal Germany, www.karldeutsch.de

1 Introduction

This paper discusses various applications where the ultrasonic weld inspection is carried out in an automated manner. The highest throughput rates are required in pipe mills where the testing systems are part of the production line and should not limit the capacity of the mill. The systems often work in 3-shift operation with a rate of availability of more than 90%. Therefore, robust testing mechanics are combined with sophisticated multi-channel ultrasonic electronics which allow trouble-free operation in an industrial environment with many electro-acoustical noise sources (motors, transformers, welding equipment).

2 Ultrasonic Coupling techniques

Since air is a poor conductor for ultrasound, **water** is commonly used **for the ultrasonic coupling**. This usually governs the design of every testing system. The principal ways to couple ultrasound into the specimen during an automated weld inspection are now discussed:

Immersion testing is a very common method for smaller specimens being inspected piece by piece, e.g. automotive components. Usually the entire specimen is immersed in water and a stage carrying the ultrasonic probes is moved with respect to the component. The scanning pattern can be more or less automated depending on the desired through-put, test areas and coverage. The degrees of freedom for moving the probes is mainly governed by the geometry of the component. In most cases, x-y-scans are carried out producing a test report such as a C-scan.

For an on-line inspection of long profiles, a water-filled test chamber can be used. Only a short section of the profile is then immersed. Only few immersion test setups are encountered in pipe weld inspection. An exception could be small-diameter ERW-pipes which are tested in systems which are typically used for the inspection of seamless pipes. The pipe diameters for such systems range up to approx 170mm. If the weld position is known then the immersion chamber can also be partially equipped with ultrasonic probes. This is sometimes done for the online inspection of endless ERW-pipes directly after the welding point. The high temperatures on the pipe surface endanger stable coupling and therefore such testing setups are rarely used.

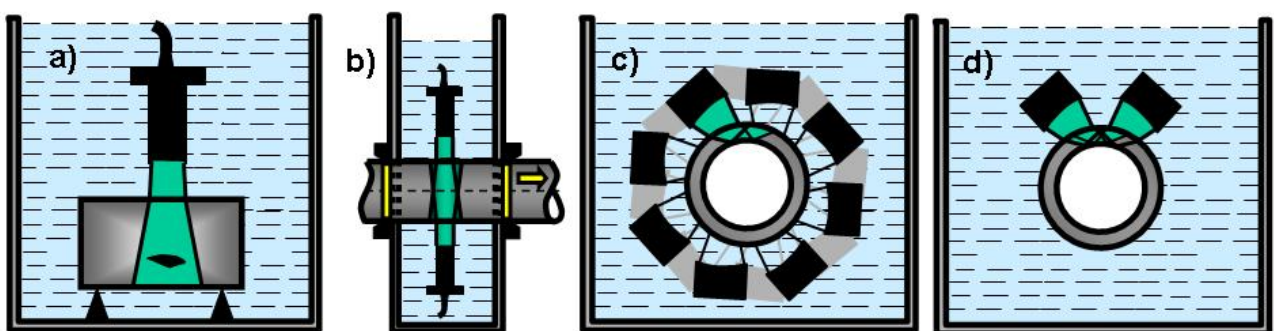

Fig. 1: *Immersion Testing. a) Immersion testing for component test, b) HRP-immersion high-speed testing for long profiles (bars & pipes), c) HRP-immersion testing of small diameter ERW-pipes with setup for seamless pipe, and d) HRP-immersion setup with probes only for weld inspection in 12 o'clock position.*

For larger pipe diameters the growing ovalities suggest a probe guidance on the pipe surface and therefore other coupling concepts. Two coupling methods are mostly encountered in industrial applications. One technique is commonly called **water gap coupling**. The probe is mounted into a probe carrier and the distance of the probe face to the pipe surface is in the order of 0.5 mm. The probe carrier is guided along the pipe surface by rollers or by

Automated Ultrasonic Pipe Weld Inspection

shoes. For strong curvatures of the pipe surface, i.e. small pipe diameters, curved shoes have to be used and the gap might need fine adjustment within the probe carrier. There are some advantages to this technique: Dual-element probes can be applied, thus offering only small untested zones at the front and back surface of the pipe. Secondly, large face probes can be used in order to achieve a wide test trace per probe. Typically, the test trace is limited to 25 mm for one probe in order to ensure stable coupling conditions and to find the required defect size. The amount of coupling water for gap coupling is rather small which reduces the requirements on the water circulation system.

If the weld geometry (weld width, pipe wall thickness) requires various incidence angles, probes with those incidence angles have to be mounted (resulting in long change-over times for the testing system and a large number of required probes). The disadvantage of rather high probe and shoe wear (especially for rough or black pipe surface), the need of many sets of curved shoes and probe angles and the limited test speed (typical 0.5 m/sec) have led to the introduction of **water jet coupling** (also called squirter technique) by KARL DEUTSCH in the 1970's. Water jet coupling offers a higher near-field resolution and longer lifetime of the probes. A water jet is guided within a plastic nozzle towards the component surface. The jet diameter has to be large enough to carry the entire ultrasonic beam and has to be without air bubbles and turbulences for a good ultrasonic signal-to-noise ratio. Straight-beam immersion probes are used. A fairly long water column (30 – 50 mm) between probe and component guides the ultrasound. In order to produce angle incidence, the entire probe carrier is mechanically tilted with respect to the component surface. This technique is basically free of wear. Only the shoes or rollers which guide the probe carrier along the pipe surface have to be changed from time to time. Testing speeds of up to 2 m/sec are possible. With this technique, compact multi-probe carriers were patented by KARL DEUTSCH more than 25 years ago for the inspection of pressure cylinders. Other common applications of water jet coupling are bar testing and billet testing.

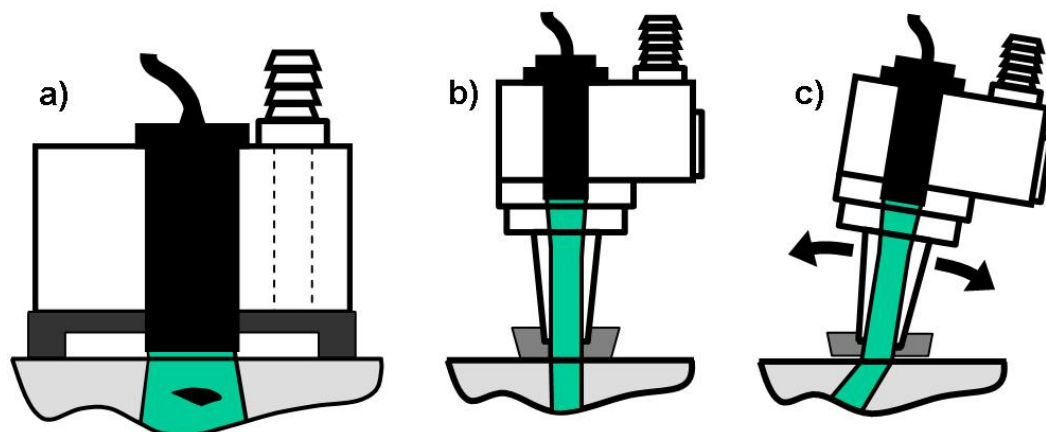

Fig. 2: *Gap and Jet Coupling, a) gap coupling, typically used for lamination and strip testing with dual-element probes, b) wear-free jet coupling with straight-beam incidence, c) jet coupling with angular incidence for high-speed weld inspection and convenient angle adjustment.*

Several alternate methods have been explored to avoid water for ultrasonic coupling. Wheel probes, electromagnetic transducers (EMAT) and laser ultrasound are such approaches. Each approach has shown advantages and disadvantages. It remains to be said, that water coupling dominates in industrial use.

3 Common Test Tasks for the Ultrasonic Inspection of Welded Pipes

For weld inspection in pipes, the cross-section to be tested is reduced to the weld itself and to the heat-affected zones besides the weld. The welding process is already automated in order to make an automated testing system worthwhile. The common detection and measurements tasks are:

- Longitudinal defects (internal, external, mid-seam)
- Longitudinal Defects with perpendicular orientation with respect to pipe surface (tandem setup)
- Transverse Defects (internal, external)
- Lamination Testing within the Heat-affected Zone (HAZ)
- Wall Thickness Measurement (over weld for ERW-pipes, in HAZ for SAW-pipes)

(SV) AutomatedUT WeldedPipes (WCNDT-Shanghai) WD Jan08.doc 31.Jan-2008

- Pipe End Inspection for Laminations (and sometimes also for Longitudinal Defects)

Each test task requires the respective incidence angle resulting in a testing system with a multitude of electronic channels and probes. The **use of probe pairs centred with respect to the weld** allows for the detection of typical oblique defects within the weld and also for using the through-transmission signal for constant coupling check between the two probes. If the V-transmission signal is missing or weakened, either the coupling, the probe or the entire system is not working correctly. Thus, the transmission signal is constantly supervised and ensures the stable operation of the system. If the typical ultrasonic sound beam diameters can not cover the entire wall thickness, more than one probe pair has to be used.

3.1 Detection of Longitudinal Defects

Longitudinal defects require approximately one probe pair for every 7-10 mm of pipe wall thickness. Thin walled ERW-pipes can therefore be inspected with one probe pair. Many testing systems make use of two probe pairs, using one probe pair for the internal pipe wall and the second pair for the external pipe wall. Many common international test specifications can be fulfilled with this setup. The test defects are external and internal notches of longitudinal orientation. As an alternative, through-drilled holes centred with respect to the weld are used.

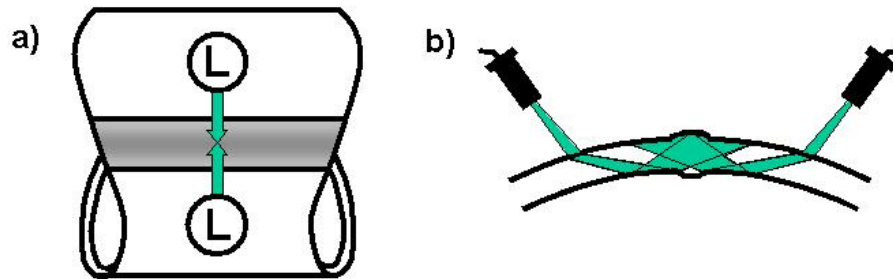

Fig. 3: **Longitudinal Defect Detection.** a) top view of probe pair with angular incidence with respect to weld, b) cross-sectional view of probe pair and pipe, here shown for the detection of external defects.

Heavy-walled pipes might require additional probes for the detection of **longitudinal mid-seam defects**. For LSAW-pipes with walls up to 50 mm, up to five probes pairs are used. Only in case of ERW-pipes, longitudinal defects perpendicular to the pipe wall might occur since the strip edges are almost straight and without bevel. One or more **tandem setups with four probes** (two on each side of the weld) are then required. In case of SAW-pipes, the weld seam material is completely molten and therefore, an incomplete bond between the weld bevel surfaces hardly occurs. The use of tandem testing systems is required in some testing specifications but its use remains questionable.

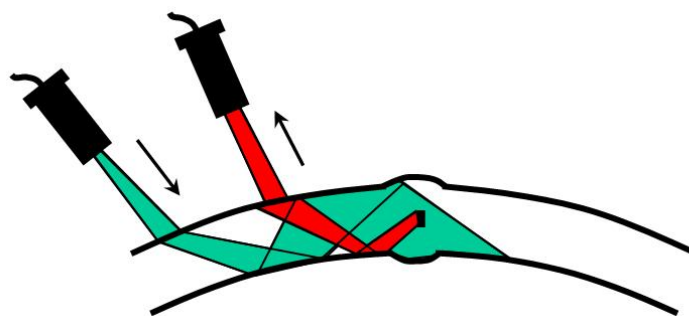

Fig. 4: **Tandem Testing.** Defects in mid-seam are detected with a two-probe setup, one probe acting as a transmitter and one probe as a receiver.

3.2 Detection of Transverse Defects

Transverse defects hardly occur during the production of ER-welded pipes. Therefore, ERW-pipes are often not tested for transverse defects. Anyhow, one on-bead probe pair is sometimes installed – maybe just to satisfy the test specification of a single customer. The on-bead inspection is of course the best-possible way to insonify transverse defects since each probe can be used in pulse-echo mode. In case of SAW-pipes, only inclusions or pores within the weld might show transverse reflectivity. Since the weld bead of SAW-pipes is not machined, the coupling and guidance of the probes is more difficult and requires a sophisticated testing mechanics.

Conventional testing systems for SAW-pipes use the **K or X-configuration** where two/four probes are mounted next to the weld. Two probes work as transmitter – receiver arrangement and their V-reflection signal is used to detect transverse defects. This setup then requires perfect positioning of two probes with respect to the weld and also a rather complicated mechanical adjustment with respect to the pipe geometry (wall thickness, pipe diameter).

Therefore, modern testing systems for SAW-pipes make use of water jet coupling for an **on-bead transverse flaw detection**. Although the weld surface for SAW-pipes is not perfectly smooth, the ultrasonic coupling can be achieved with proper design of the probe holders. The incidence angle is typically 45 degrees and only the distance of the two probes might need adjustment for coupling check purposes (V-transmission).

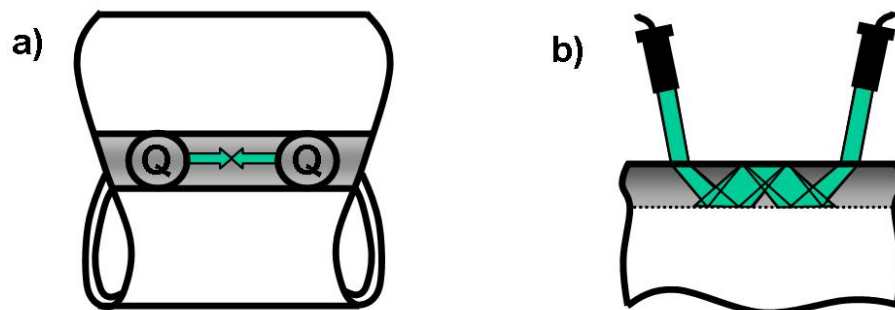

Fig. 5: **On-Bead Transverse Defect Detection.** a) Top view of on-bead probe pair with respect to weld, b) cross-sectional view of probe pair and pipe.

3.3 Detection of Laminations

Besides the weld itself, the heat-affected zone (HAZ) deserves special attention. In many cases, pre-inspected strips or plates are used for the pipe production. In that case, the **inspection for laminations within the HAZ** might be omitted. Most international specifications allow for either inspection of the strip edges before pipe forming OR the lamination inspection on the welded pipe. Dependent on the type of pipe and the used test specification, a test trace of 15 – 25 mm on both sides of the weld is inspected. For strong pipe curvatures, two probes should be used on both sides of the weld to ensure straight-beam incidence. Dual-element probes are used in order to ensure small dead zones on internal and external pipe surface. If high testing speeds are required, jet coupling with straight-beam probes is employed.

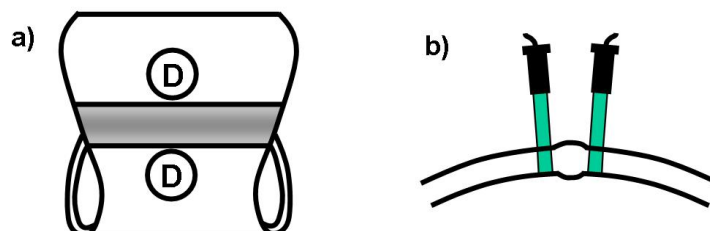

Fig. 6: **Lamination Testing within heat-affected zone.** a) Top view of probe pair position with respect to weld, b) cross-sectional view of probe pair and pipe.

Automated Ultrasonic Pipe Weld Inspection

Dependent on the type of pipe, the pipe body might require further lamination inspection (**full-body test**). If an ERW-pipe is used instead of a seamless pipe, also the ultrasonic inspection is similar to seamless pipe testing (mostly detection of longitudinal defects). This will not be further discussed in this paper.

Longitudinally submerge-arc-welded pipes (**LSAW-pipes**) for later pipeline usage are mostly produced from heavy plates which are pre-inspected for laminations with high coverage in the strip mill. Therefore, in the LSAW-pipe mill, the pipe body is not further tested with ultrasound.

Helically submerge-arc-welded pipes (**HSAW-pipes**) use steel coils as input material. The coils are usually not pre-inspected. For those coils, the full-body inspection is often carried out after the welding process in an oscillating manner. A strip inspection before pipe forming is rarely used. The problem of strip testing directly before welding is the coupling water. The water has to be entirely removed before welding for not disturbing the welding process. Limited space on the uncoiling machine makes this a difficult task.

The pipe body of electrically welded pipes (**ERW-pipes**) either inspected as strip or on the finished pipe after the hydrotest. In the latter case, helical test traces (rotating pipe, linear probe movement) and a coverage between 12.5 and 25% of the pipe body is typical. Dependent on the desired throughput, the number of probes is chosen accordingly. Typical setups have eight to sixteen dual-element probes and a probe spacing of 100 mm. Testing speeds also with dual-element probes up to 1.5 m/sec are possible.

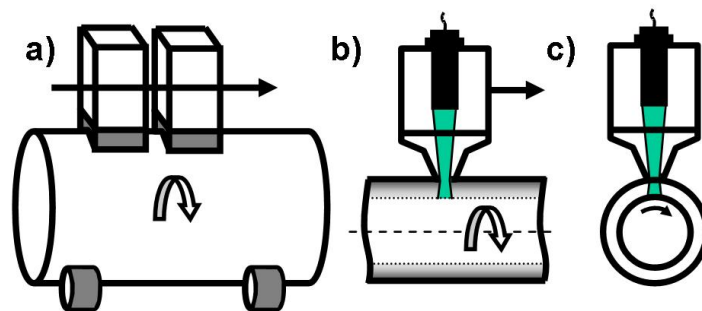

Fig. 7: Full-Body testing and/or pipe end test with helical test traces. **a)** one or more probe carriers move along the rotating pipe, **b)** straight-beam incidence, and **c)** cross-sectional view of full-body and/or pipe end test.

3.4 Wall Thickness Measurement

The **wall thickness measurement** on welded pipes is not as common as for seamless pipes since in most cases the strip or plate thickness does not change much during the production process. As a constant supervision of the welding procedure for **ERW-pipes**, a **oscillating deburring check** with wall thickness measurement directly after welding is carried out. One probe holder with a straight-beam probe oscillates across the weld while the tube is linearly moved. Setups with shockwave immersion probes using jet coupling are used. The oscillating range covers the weld and the region besides the weld (parent strip material). The oscillating frequency is in the order of 1 Hz while the endless pipe is transported with a speed between 10 and 35 m/min. The major task of the deburring check is to supervise the deburring tool instead of a high-precision wall thickness measurement. If the internal pipe wall is not parallel to the external pipe wall, no ultrasonic signal is received. Therefore, this method basically produces a ok/not-ok-information about the deburring process.

Sometimes, the lamination probes (for the HAZ) of SAW-pipe testing systems are also used for a wall thickness measurement next to the weld.

3.5 Pipe End Testing

The **pipe ends** deserve special attention. If the pipes are used for pipelines for the transportation of fluids (water, oil or gas), they are circumferentially welded in the field. For ERW-pipes, the pipe end zone to be inspected for laminations is typically 25 – 50 mm. Also, the part of the weld which was not covered by the automated weld testing system (typical 100 mm) should be further inspected – either manually with a portable flaw detector and angle-beam contact-probes or in an automated manner. For SAW-pipe ends, the ultrasonic test should cover

Automated Ultrasonic Pipe Weld Inspection

50 mm. Again, the untested portion of the weld should be inspected with angle-beam probes for longitudinal defects. Many test specifications require an additional magnetic particle test of the end bevel and the weld close to the pipe end (typically 300 mm).

The ultrasonic pipe end test can be integrated into the ultrasonic weld testing system using separate probe carriers for that purpose. The probes are usually placed onto the external pipe wall in the 12 o'clock position while the pipe is rotating.

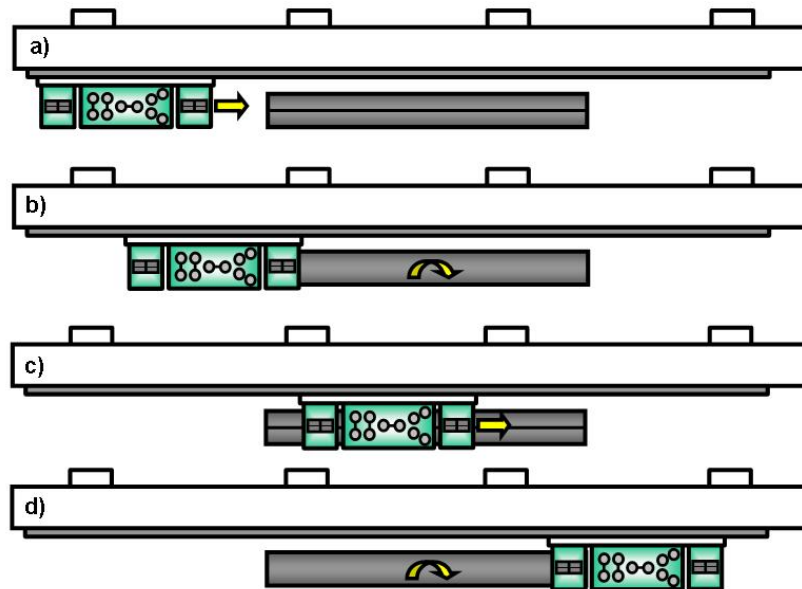

Fig. 8: **Testing Portal** for weld and pipe end testing. **a)** Approach of testing carriage towards resting pipe, **b)** test of front pipe end, **c)** weld testing with weld in 12-o'clock-position, and **d)** test of second pipe end.

If separate pipe end systems are used, the pipe end can either be inspected from the internal or external pipe wall. Using the internal pipe wall allows for a probe movement closer to the pipe end (no bevel on internal pipe wall) and therefore producing shorter untested ends (<10 mm).

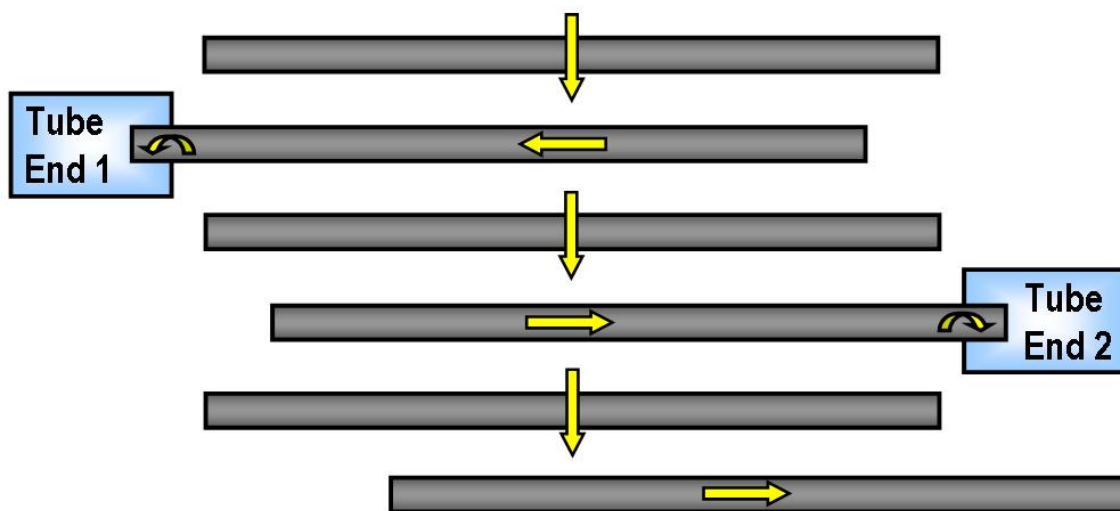

Fig. 9: **Pipe-End Systems.** Principle of pipe transport for testing both pipe ends in separate testing systems.

4 Ultrasonic Inspection of ERW-Pipes

The production of ERW-pipes includes several steps of nondestructive testing (NDT). The usage of NDT has two major goals: Early information about the welding procedure as a feedback for the production line and secondly, the final inspection of the finished pipe.

Up to four ultrasonic systems are typically encountered during the production process. A strip tester is used if the steel coils were not tested at the strip mill before. Linear or oscillating test traces of the probes are possible. The strip edges (typically 25 - 50 mm) are tested with separate probes. Directly after welding, a first online weld test is carried out with ultrasound. It is common to check for longitudinal defects only. Sometimes, an oscillating deburring check is added. After pipe cutting and the hydrostatic test, the final inspection is carried out. A probe pair for transverse defect detection might be included. The SHELL-specification also requires tandem testing for longitudinal defects for larger wall thickness.

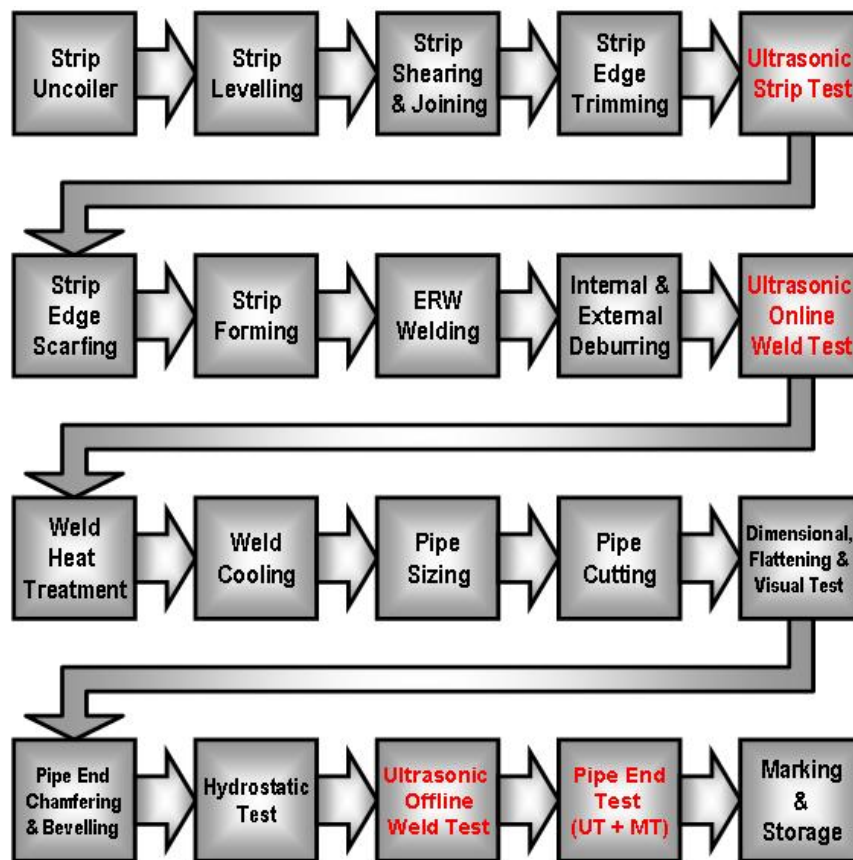

Fig. 10: Example for ERW-pipe production.

Dependent on the required throughput and the test specification, the same or a separate testing system is used for the pipe end and/or full-body inspection. If the same testing system is used for both test procedures, a testing portal with moveable carriage is common. The testing portal shows the advantage that the weld is inspected without pipe movement, thus avoiding vibrations which could degrade the test results. In a second step, the carriage is moved backwards while the pipe is rotating. Either the pipe ends are tested or the entire pipe body is tested in helical test traces. The typical throughput for such a combined testing system is 60 pipes/hour.

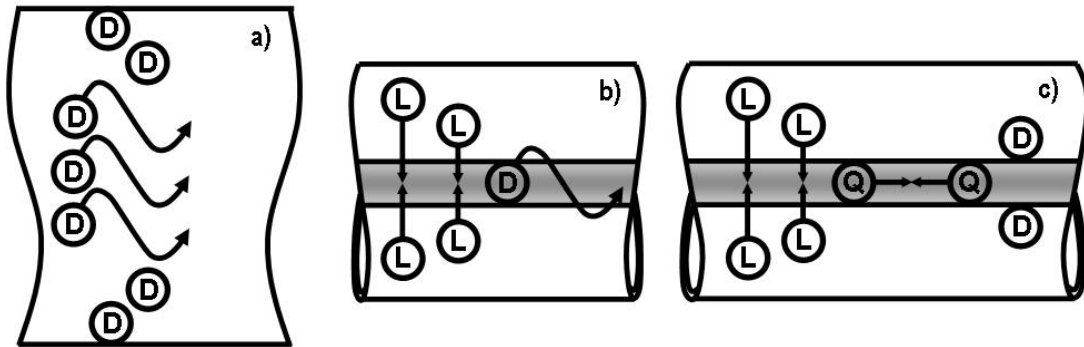

Fig. 11: Typical Probe Configuration for ERW-pipe inspection. **a)** Strip inspection with edge probes and oscillating strip middle probes, **b)** online weld test with 4 probes for longitudinal defect detection and an oscillating deburring check, and **c)** offline weld inspection with 4 probes for longitudinal defect detection, 2 probes for transverse defect detection and 2 probes for lamination testing in the heat-affected zone.

5 Ultrasonic Inspection of HSAW-Pipes

Helicallly welded pipes are typically produced from diameters from 350 – 2500 mm. They are used for water pipelines, but also for the transportation of other fluids (e.g. oil and gas). More or less extensive NDT is carried out in accordance to the later pipe usage. In comparison to LSAW pipes, spiral pipes are fairly easy to produce, because the width of the input strip material can be used for a large pipe diameter range, dependent on the weld angle. On the other hand, the control of the welding head and the weld test require careful position control and the output of a spiral pipe mill is rather limited. The pipe wall is limited to about 25 mm.

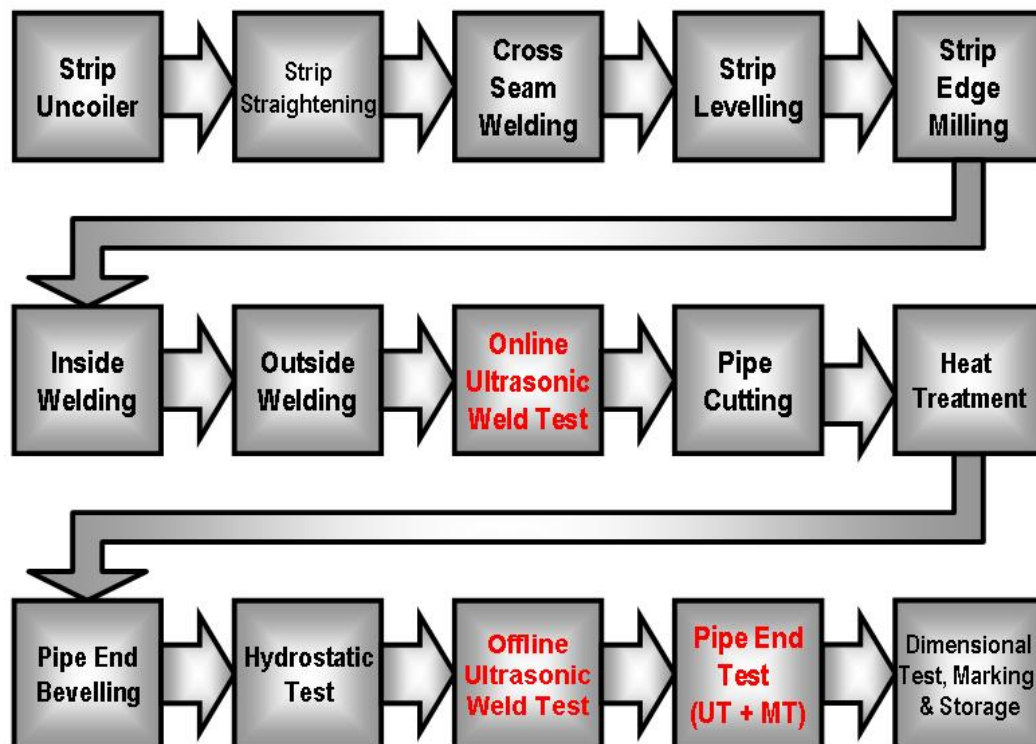

Fig. 12: Example for HSAW-pipe production.

The first ultrasonic weld inspection is carried out directly after welding. The probes are mounted to a stationary machine stand which is height-adjustable in accordance to the pipe diameter. The test position is in 12 o'clock. The motor for the seam tracking is mounted to the cantilever beam to centre the probe pairs with respect to the weld. It

Automated Ultrasonic Pipe Weld Inspection

is always checked for longitudinal defects with one or two probe pairs. Transverse defect detection (K-arrangement) and lamination detection are often added.

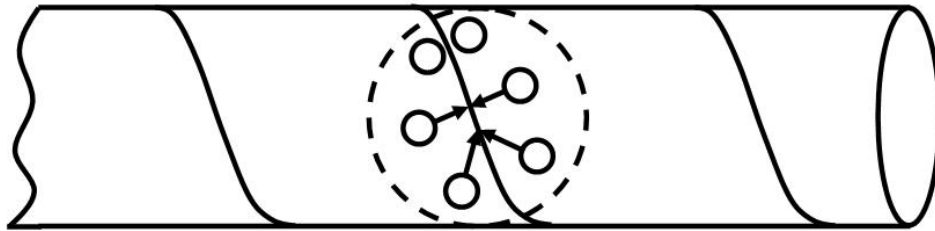

Fig. 13: **Online-Ultrasonic Weld Test** directly after welding with six probes (2 longitudinal, 2 transverse, 2 laminations).

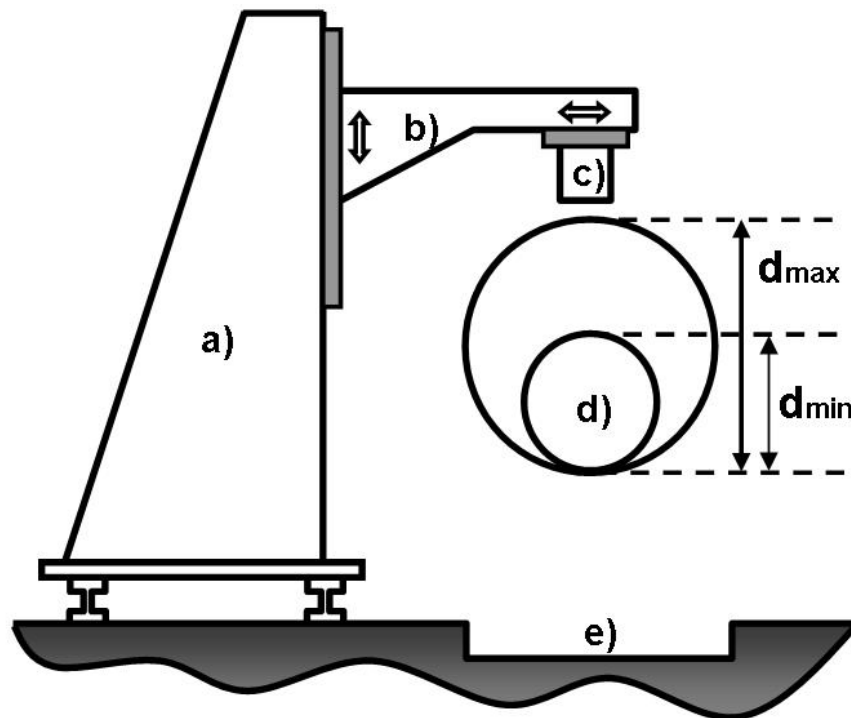

Fig. 14: **Testing mechanics for spiral pipe inspection.** **a)** Machine frame (stand), **b)** cantilever beam (boom) with vertical adjustment, **c)** probe carriers with horizontal position adjustment, **d)** spiral SAW-pipe, and **e)** foundation with water drainage (closed water circuit).

After pipe cutting, a second ultrasonic test is performed offline. The number of probes is equal or higher than during the first inspection, because this inspection is important for the final customer of the pipe. Since the testing mechanics have to be adjustable in accordance to the weld angle, space is rather limited and for more than four probe pairs, a second weld testing mechanics and a second machine stand is supplied. Longitudinal probe pairs, sometimes tandem probes, transverse and lamination probes are supplied. Since water is critical to the welding process, the strip inspection is often carried out after the hydrostatic test. To increase the coverage for each probe, oscillating probe movements are typical. The weld and strip inspection requires a smooth helical pipe movement with respect to the probes, making the seam tracking a difficult and important task.

The pipe end inspection can be done in the same setup and requires one pipe rotation for each pipe end. The probe carriers are typically guided by rollers on the pipe end for short untested ends.

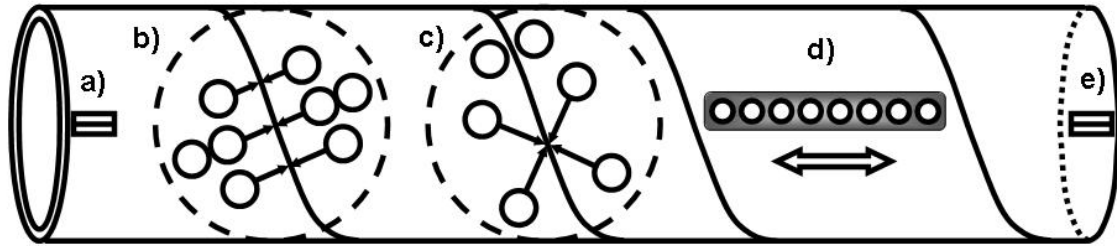

Fig. 15: *Ultrasonic offline test after hydrostatic test with 22 probes. a) front pipe end testing, b) longitudinal defect detection – internal, external and mid-seam tandem, c) transverse defect (X-configuration) and lamination detection, d) oscillating strip inspection between the welds, and e) second pipe end testing.*

6 Ultrasonic Inspection of LSAW-Pipes

Most LSAW-pipes are heavy-walled with typical diameters between 500 – 1600 mm for the transportation of oil and gas, and therefore extensive NDT is carried out. The production of LSAW-pipes is divided into two major parts – before and after the hydrostatic test. This test is an important step within the process, because the pipe can still be repaired if defects are found in an early stage. Once the hydrostatic test is performed, a defective pipe can not be saved. NDT on both sides looks rather symmetrical. An initial ultrasonic test produces early feed back about the production quality. Sometimes, the first ultrasonic test is even carried out with higher sensitivity than the second and final test. Defective areas are double-checked with X-rays. The same pair of nondestructive tests is carried out after the hydrostatic test. Finally, the pipe ends are checked for laminations with ultrasound, X-rays and sometimes also with magnetic particles.

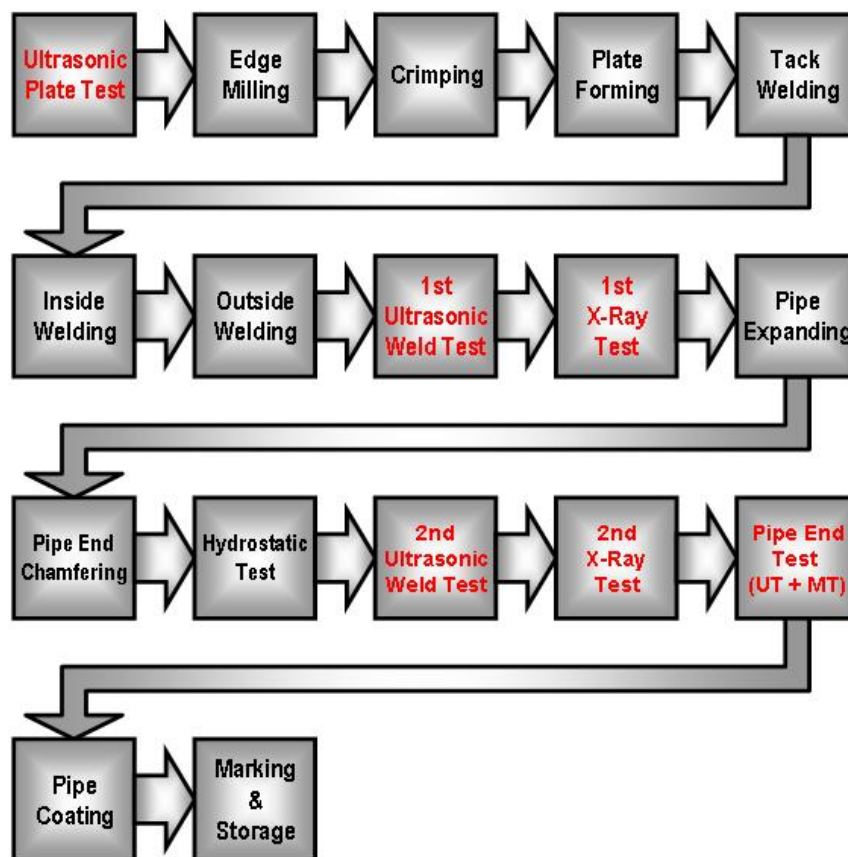

Fig. 16: *Principle of LSAW-pipe production.*

The inspection for longitudinal and transverse defects within the weld is always mandatory. Heavy pipe walls might require several (typically up to 5) pairs of longitudinal probes. If SHELL has to be fulfilled, also tandem

Automated Ultrasonic Pipe Weld Inspection

testing for longitudinal mid-seam defects might be applied. Even though the heavy plate is usually pre-inspected, the lamination probes are typically supplied for such systems.

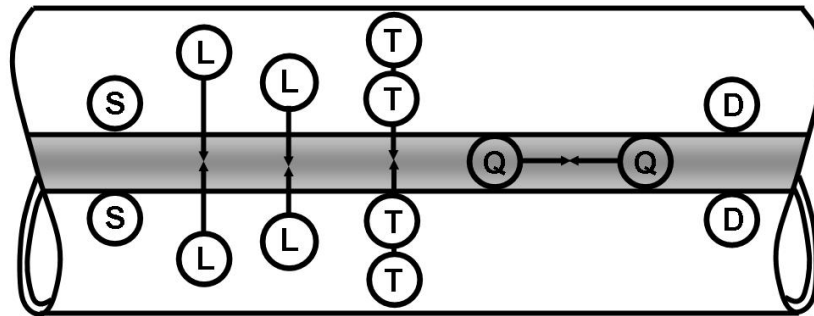

Fig. 17: Typical Probe Configuration for LSAW Pipe Inspection, S = seam-tracker, L = Longitudinal defect detection on internal and external pipe wall, T = tandem testing for mid-seam defects, Q = on-bead transverse defect detection, and D = lamination testing within heat-affected zone.

7 ECHOGRAPH Ultrasonic electronics

The evaluation of the ultrasonic signals is carried out with multi-channel electronics. The electronics can be programmed according to all previously mentioned testing tasks. In general, a multitude of channels is necessary and each channel can be individually configured. The robust environment in a pipe mill suggests to use external pre-amplifiers close to the ultrasonic probes. The probes cables have to be well shielded and the electronics need a large amplification range with high signal-to-noise ratio.

PC-based electronics have shown difficulties in the pipe mill. The PC as an operation platform typically uses a Windows-operating system. This platform shows problems with real-time applications such as ultrasonic testing. Secondly, external noise sources such as motors and welding equipment close to the ultrasonic system impose serious danger of degrading the ultrasonic results. Therefore, common test electronics use the PC only as an operating platform and as a user friendly interface. The PC allows for setting the system parameters and collects the test data for visualisation and storage purposes. The data transfer into a higher ranked network is commonly carried out.

Signals from all channels are processed in real-time. Each channel is equipped with four gates and with up to three thresholds. Gates and thresholds can be individually set for each channel. A fast programmable distance amplitude correction (DAC) is implemented which compensates the acoustic damping for increasing travel time. The result is a very even testing sensitivity. The DAC can also be programmed differently for each channel.

As a supplement to the electronics, a data management system is provided. The test data are processed according to the customers needs using an industrial PC. Test protocols are generated, the test parameters are stored for quick retrieval and therefore for short change-over times. A Windows -operation system allows for a convenient operation of the entire testing system.

An extra electronic module is responsible to combine the ultrasonic data and the data from the position sensors which record the relative movement between probe(s) and specimen. The specimen is subdivided in so-called test intervals where the spatial resolution can be chosen. An on-line display of all signal amplitudes with respect to the specimen position is shown on the PC-screen. Exceeding of the pre-set amplitude thresholds is clearly visible and helps the operating personnel to supervise the current inspection. The system operator decides on the type of documentation and on the amount of data which has to be stored. Graphical documentation, tabulated text and a statistical evaluation of the test data are available. A statistical evaluation contains all collected data, e.g. for an entire batch or a working shift.

8 Summary

This article contains a brief overview on automated ultrasonic welded inspection for various pipe types. Some inspection steps might be carried out with portable test equipment (e.g. pipe end test), but the weld inspection in all internationally relevant specification must be automated. The pipe geometry, the production process, and the pipe usage determine the number of required probes. Recent updates for some test specifications enforce a large number of ultrasonic probes, e.g. the SHELL standard. Since seamless pipes are sometimes replaced by ERW pipes and LSAW pipes by SSAW pipes (in both cases to save production cost), the inspection methods change gradually between the various pipe types. Each testing system is unique and shows its specialties which have to be discussed by supplier, testing system user and final customer of the pipe.

9 References

- [1] V. Deutsch, M. Platte, M. Vogt: Ultraschallprüfung – Grundlagen und industrielle Anwendungen (Ultrasonic Testing – Principles and Industrial Applications), 372 pages, Springer Publishing House, 1997.
- [2] V. Deutsch, M. Platte, M. Vogt, W. A. K. Deutsch, V. Schuster: Ultrasonic Testing – Compact & Understandable, 77 pages, Castell Publishing House Wuppertal, 2002.
- [3] W. A. K. Deutsch: Automated Ultrasonic Inspection – Examples from the Steel Mill, WCNDT World Conference for Nondestructive Testing, Rome Italy, October 2000.
- [4] W. A. K. Deutsch, V. Schuster: Automated Ultrasonic Testing Systems – Considerations about Throughput, Coverage and Sensors (Automatisierte Ultraschall-Prüfanlagen – Überlegungen zu Durchsatz, Überdeckung und Sensorik), DGZfP NDT - Seminar, Saarbrücken, October 2003.
- [5] W. A. K. Deutsch, V. Schuster: Ultrasonic Testing during Production - Semi Finished-Product or Component Testing, BANT-KINT Symposium on Nondestructive Testing, Liege Belgium, March 2005.
- [6] P. Möller: Ultrasonic Testing Applications with Probe Holders with Water Jet Coupling (Ultraschall-Prüfanwendungen mit Prüfkopfträgern für die Wasserstrahl-Ankopplung), DGZfP Conference Proceedings, Garmisch, p. 109-117, 1993.
- [7] W. Deutsch, V. Schuster, M. Joswig, R. Kattwinkel: Fast Automated Bar and Tube Testing Without Rotation, (Schnelle, automatisierte Stangen- und Rohrprüfung ohne Rotation), DGZfP Conference Proceedings, Celle, p. 407-415, 1999.
- [8] M. Platte, P. Möller: Automated Ultrasonic Testing of Strips and Tubes (Automatisches Ultraschallprüfen von Blechen und Rohren), Bänder Bleche Rohre, p. 25-32, March 1993.
- [9] P. Möller: Automated Ultrasonic Testing of Pressure Cylinders with Compact Multi-Probe Holders (Automatische Ultraschall-Prüfung von Stahlflaschen mit kompakten Mehrfach-Prüfkopfträgern), DGZfP Conference Proceedings, Garmisch, p. 589-593, 1993.
- [10] ISO 9756:1990(E): Submerged arc-welded steel tubes for pressure purposes – Ultrasonic testing of the weld seam for the detection of longitudinal and/or transverse imperfections.
- [11] ISO 12094:1194(E): Welded steel tubes for pressure purposes – Ultrasonic testing for the detection of laminar imperfections in strips/plates used in the manufacture of welded tubes.
- [12] ISO 3183-3:1999(E): Petroleum and natural gas industries – Steel pipe for pipelines – technical delivery conditions, Part 3: Pipes of requirement class C.
- [13] SHELL DEP.40.20.37-Gen.: Linepipe for critical Service (Amendment/Supplements to ISO 3183-3), Dezember 2000.
- [14] API Specification 5L: Specification for Line Pipe, Ausgabe März 2004.
- [15] Det Norske Veritas OS-F101 Submarine Pipeline Systems, Appendix D: Non-Destructive Testing, Januar 2000.