



ECHOGRAPH Probes

Sensors and Accessories for Ultrasonic Testing

KARL DEUTSCH

KARL DEUTSCH Pruef- und Messgeraetebau, Wuppertal Company Portrait

The privately owned company KARL DEUTSCH founded in 1949 develops and produces instruments for non-destructive material testing. Portable instruments, stationary testing systems, sensors and crack detection liquids are produced by 130 motivated employees in two works in Wuppertal. Additional 20 employees in international offices and a worldwide network of dealers support the export business which accounts for more than 50% of the turnover.

Our customers are metal producing and processing industries, e.g. steel works, automotive companies and bearing manufacturers. Typical test tasks are ultrasonic weld testing, detection of shrink holes in castings, crack detection in forgings with magnetic particles and dye penetrants, safety components for railway and aerospace as well as wall and coating thickness measurement.

Characterized by continuous innovation and product reliability, the trade marks ECHOGRAPH, ECHOMETER, DEUTROFLUX, LEPTOSKOP, FLUXA, KD-Check and RMG are well-recognized.



The staff of KARL DEUTSCH in front of a large testing system. Overall, an assembly area of 1800 m² and two overhead cranes are available in the testing systems workshop.

We have application experience, theoretical knowledge and manufacturing know-how for more than six decades. These benefits combined with standard compliant quality management guarantee state-of-the-art instruments and accessories and a leading position with regard to quality, reliability and economy also for the future.

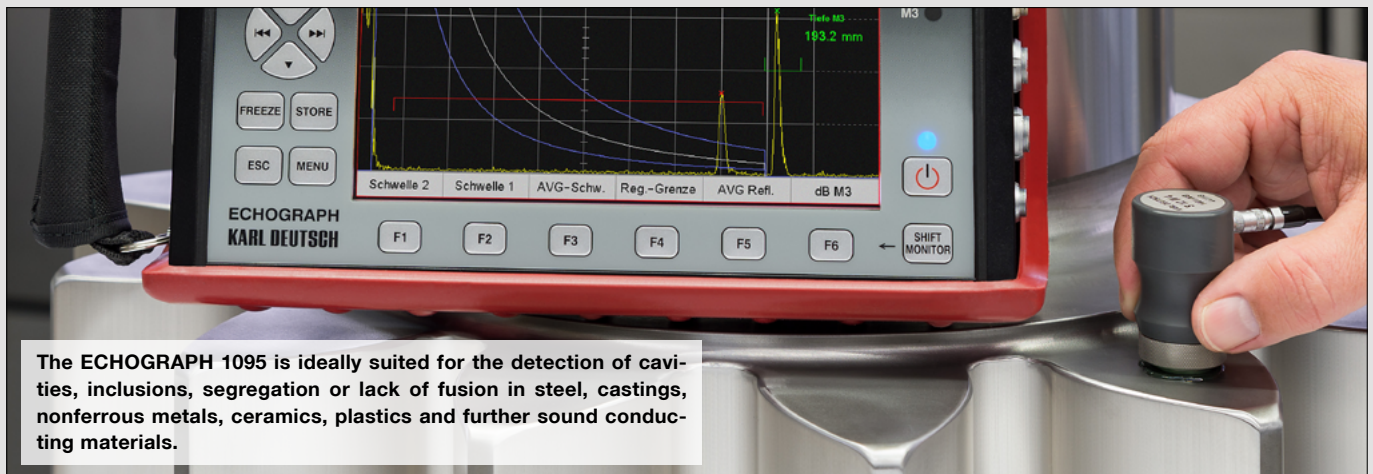

The ECHOGRAPH 1095 is ideally suited for the detection of cavities, inclusions, segregation or lack of fusion in steel, castings, nonferrous metals, ceramics, plastics and further sound conducting materials.



Probes constitute the core of ultrasonic testing. They transmit and receive the ultrasonic signal. Depending on the application, manual, immersion, system or special probes are used. Cutting edge technology and diversity are in demand here.

KARL DEUTSCH Pruef- und Messgeraetebau, Wuppertal	
Company Portrait	2
Straight Beam Contact Probes	
Probes with Protective Layer, Type W	4
Probes with Hard Wear Plate, Type H/HB	6
Heavily Damped Probes	8
TR Probes	11
TR Probes for Wall Thickness Gauges ECHOMETER 1076/1077	13
Angle Beam Probes	
Transversal Waves	15
Angle Beam Probes with Wedges	17
Longitudinal Waves	18
Angle Beam TR Probes	20
Technical Meaning of the Part Code	21
Special Probes: A Selection from our Range of Products	22
Selection Guidelines for the Choice of Ultrasonic Probes	
Probe Type	24
Nominal Frequency and Bandwidth	25
Element Dimensions	26
Wear Plate, Protective Foil or Delay line	27
Accessories	
Cables	28
Protective Foils, Retaining Rings, Handling Sleeves	28
Delay Lines, Replacement Wear Plates, Angle Beam Wedges	29
Cable Extensions	29
Adapters	30
Probe Cables for Connection to Portable ECHOGRAPH Instruments	31
Probe Cables for Connection to ECHOGRAPH Test Systems	31

This catalogue gives an overview of the standard probes for manual testing from the KARL DEUTSCH product portfolio, as well as a small selection of probes for ultrasonic testing systems and of special probes. Phased array probes for manual and automated testing can be found in the leaflet "P 14 Phased Array".

We would be pleased to advise you on the selection and suitability of probes, since we have already developed and manufactured a wide range of special probes, precisely tailored and optimized for the requirements of the special field of application.

Feel free to contact us!

E-Mail: info@karldeutsch.de
Telefon: (+49) 202 7192-0
Fax: (+49) 202 714932
Website: www.karldeutsch.de

Straight Beam Probes Protective Layer, Type W



Probes with soft protective layer

Protective layer type W

- suitable for DGS with replaceable protective foil
- small to medium bandwidth
- typical application: inspection of components with rough surface

Straight Beam Probes Protective Layer, Type W

Scale 1 : 1.5

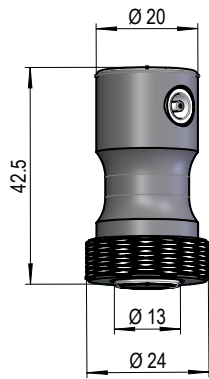

Housing S 10

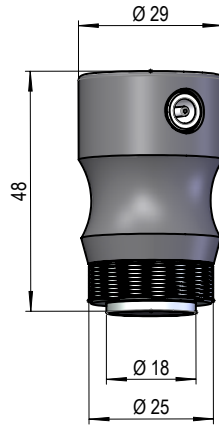

Housing S 12 W

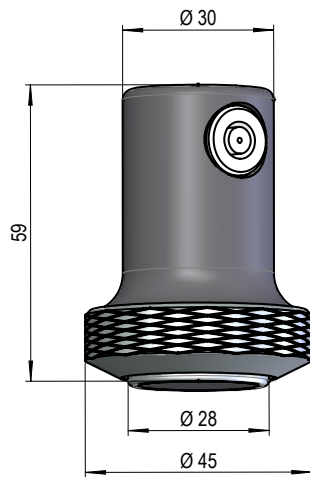

Housing S 24 W

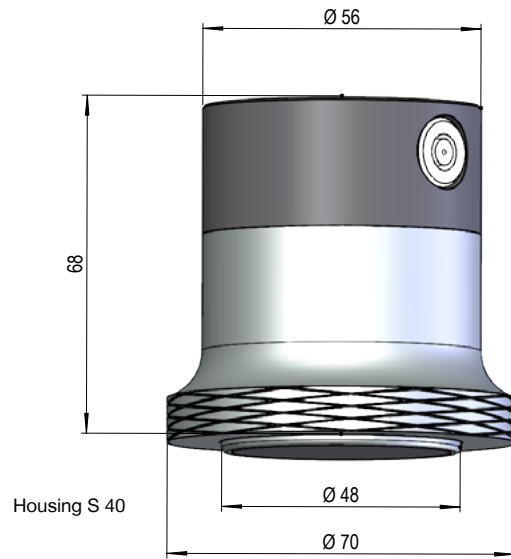

Housing S 40

Frequency [MHz]	Typical bandwidth [%]	Typical test range [mm]	Near field length* [mm]	Part code	Order no.
Element diameter 10 mm, female connector: Lemo 00, housing S 10					
2	70	50 - 500	8.5	S 10 W 2 C	1410.004
4	70	25 - 800	14	S 10 W 4 C	1410.003
6	70	15 - 1500	23	S 10 W 6 C	1410.002
Element diameter 12 mm, female connector: Lemo 00, housing S 12 W					
1	50	50 - 500	6	S 12 W 1	1401.005
2	50	25 - 1000	12	S 12 W 2	1401.004
4	50	15 - 2000	24	S 12 W 4	1401.003
6	50	10 - 2500	36	S 12 W 6	1401.002
Element diameter 24 mm, female connector: Lemo 1, housing S 24 W					
1	40	70 - 1000	23	S 24 W 1	1402.101
2	40	25 - 2000	46	S 24 W 2	1402.201
4	40	15 - 3000	87	S 24 W 4	1402.401
Element diameter 40 mm, female connector: Lemo 1, housing S 40					
1	40	70 - 1000	78	S 40 W 1	1408.007

* in steel

Straight Beam Probes Protective Layer, Type H/HB

Probes with hard protective layer

Protective layer type H/HB

- appropriate for DGS
- wear resisting protective layer
- small to medium bandwidth
- typical application: inspection of components with even surface



Straight Beam Probes Protective Layer, Type H/HB

Scale 1 : 1.5

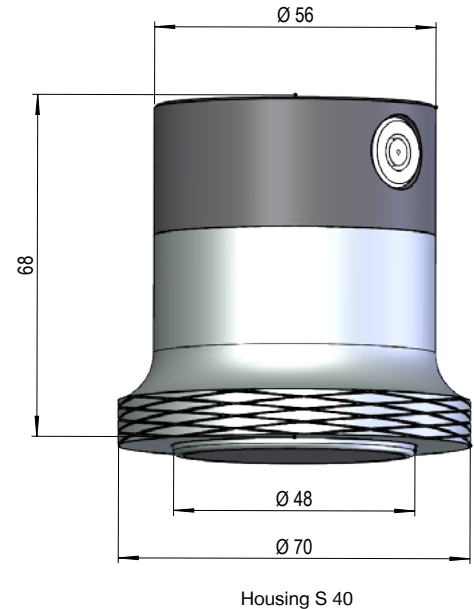
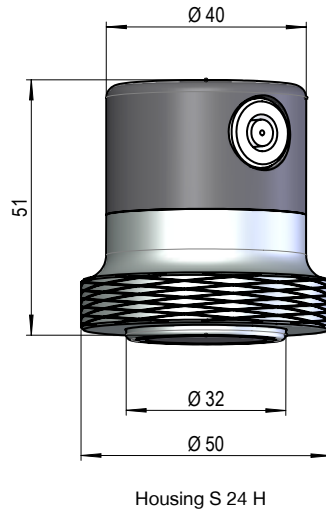
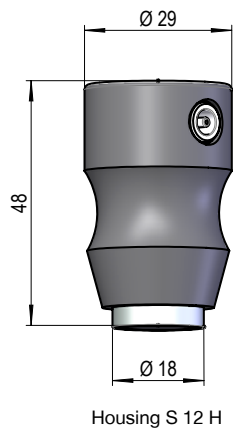

Frequency [MHz]	Typical bandwidth [%]	Typical test range [mm]	Near field length* [mm]	Part code	Order no.
Element diameter 12 mm, female connector: Lemo 00, housing S 12 H					
1	70	30 - 1500	6.5	S 12 HB 1	1411.009
2	40	25 - 3000	14	S 12 H 2	1411.006
2	70	15 - 3000	14	S 12 HB 2	1411.008
4	40	15 - 5000	27	S 12 H 4	1411.005
4	70	8 - 5000	27	S 12 HB 4	1411.003
6	40	10 - 7500	40	S 12 H 6	1411.004
6	70	5 - 7500	40	S 12 HB 6	1411.002
Element diameter 24 mm, female connector: Lemo 1, housing S 24 H					
0.5	70	100 - 500	14	S 24 HB 0,5	1412.013
1	40	70 - 1000	27	S 24 H 1	1412.007
1	70	70 - 1000	27	S 24 HB 1	1412.009
2	40	25 - 2000	52	S 24 H 2	1412.006
2	70	25 - 2000	52	S 24 HB 2	1412.008
4	40	15 - 3000	100	S 24 H 4	1412.005
4	70	15 - 3000	100	S 24 HB 4	1412.003
Element diameter 40 mm, female connector: Lemo 1, housing S 40					
0.5	60	100 - 500	36	S 40 HB 0,5	1408.005
1	60	50 - 1000	62	S 40 HB 1	1408.006

* in steel

Straight Beam Probes Heavily Damped Probes



Heavily damped probes

Wear resisting protective layer or exchangeable delay line

- extreme bandwidth, short pulse shape
- typical application:
thickness measurement,
inspection of sound scattering materials
- standard or fingertip design

Straight Beam Probes Heavily Damped Probes

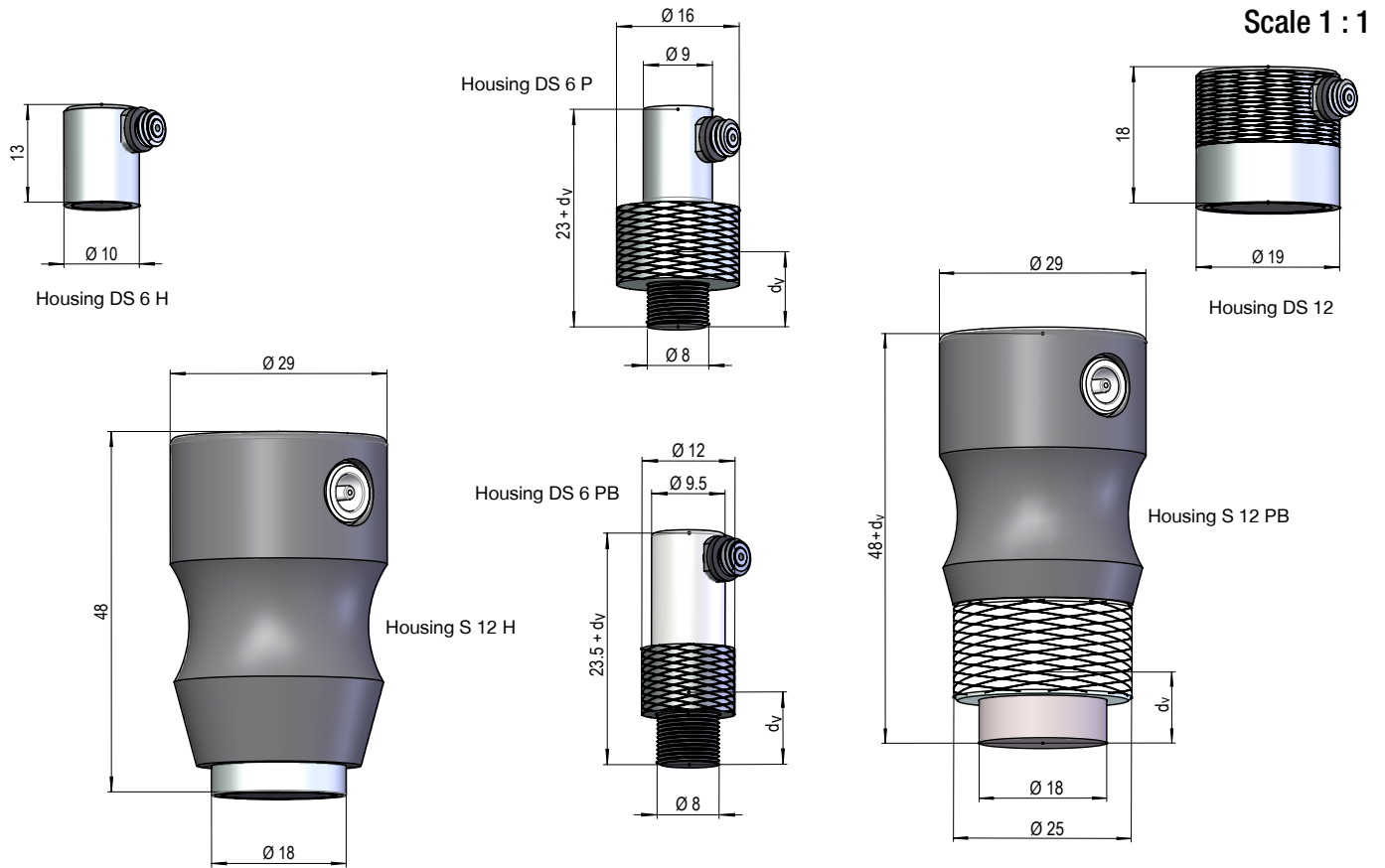

Frequency range [MHz]	Typical test range [mm]	Housing	Part code	Order no.	Note*
Element diameter 6 mm, typical bandwidth 100 %, female connector: Microdot					
2 - 7	(TP-BE): from 1.5 (BE-BE): from 1.5	DS 6 H	DS 6 HB 2-7	1432.702	-
4 - 12	(TP-BE): from 1.0 (BE-BE): from 1.0	DS 6 H	DS 6 HB 4-12	1432.701	-
4 - 14	(TP-BE): 1.0 to 2·d _v (BE-BE): 0.25 to d _v	DS 6 P	DS 6 PB 4-14	1422.001	exchangeable delay line (d _v = 10 mm)
4 - 14	(TP-BE): 1.0 to 2·d _v (BE-BE): 0.25 to d _v	DS 6 PB	DS 6 PB 4-14	1422.701	exchangeable delay line (d _v = 10 mm)
Element diameter 12 mm, typical bandwidth 100 %, female connector: Lemo 00 (except housing type DS 12)					
0.8 - 3	(TP-BE): from 2.0 (BE-BE): from 4.0	S 12 H	S 12 HB 0,8-3	1411.010	-
0.8 - 3	(TP-BE): from 2.0 (BE-BE): from 4.0	DS 12	DS 12 HB 0,8-3	1433.703	female connector: Microdot
1 - 3	(TP-BE): 2.0 to 2·d _v (BE-BE): 2.0 to d _v	S 12 PB	S 12 PB 1-3	1422.004	exchangeable delay line (d _v = 10/25 mm)
1 - 7	(TP-BE): 1.5 to 2·d _v (BE-BE): 1.0 to d _v	S 12 PB	S 12 PB 1-7	1422.703	exchangeable delay line (d _v = 10/25 mm)
1 - 8	(TP-BE): from 2.0 (BE-BE): from 2.0	S 12 H	S 12 HB 1-8	1411.001	
2 - 7	(TP-BE): from 2.0 (BE-BE): from 2.0	DS 12	DS 12 HB 2-7	1433.705	female connector: Microdot

* more delay lines to be found in section "Accessories"

Straight Beam Probes Heavily Damped Probes

Scale 1 : 1

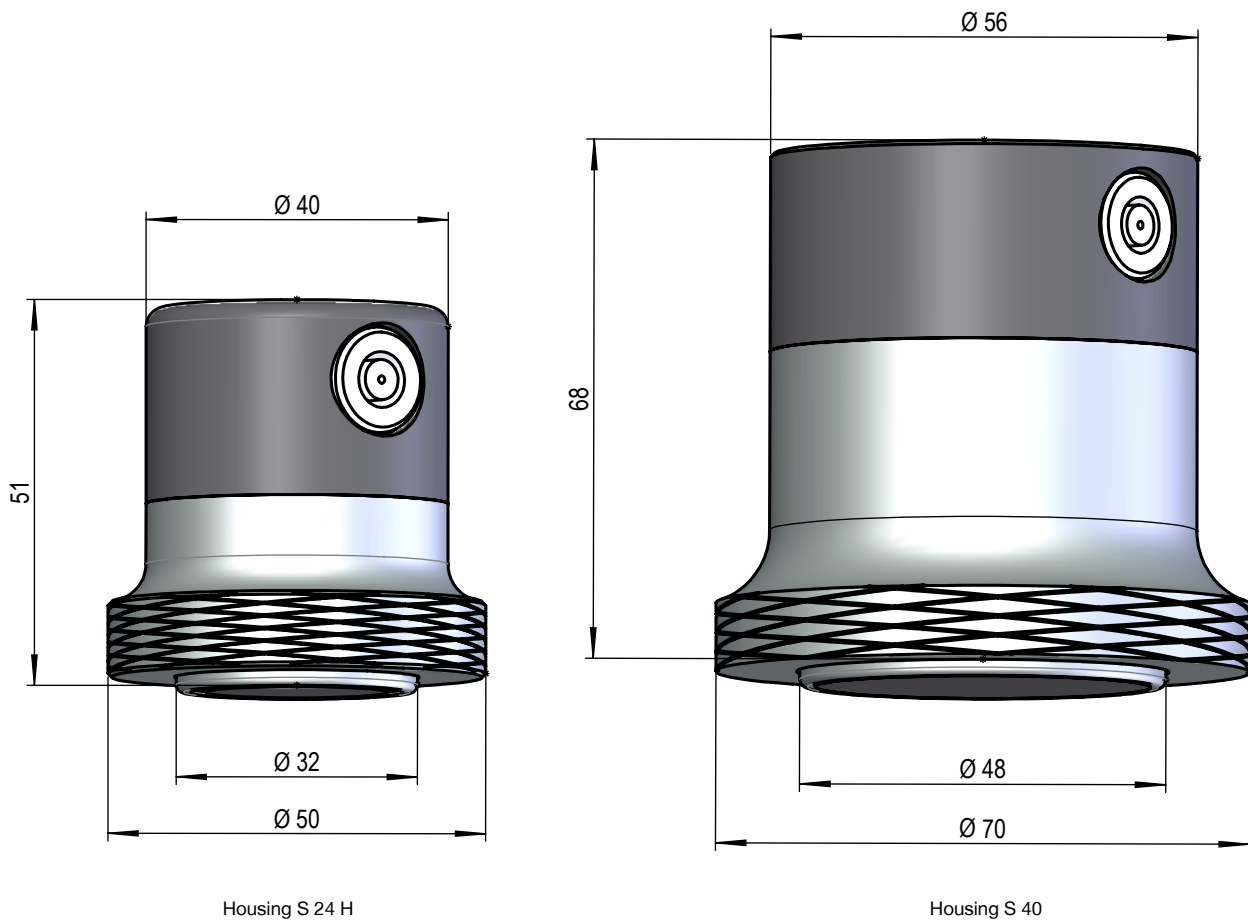

Frequency range [MHz]	Typical test range [mm]	Housing	Part code	Order no.
Element diameter 24 mm, typical bandwidth 100 %, female connector: Lemo 1				
0.2 - 0.6	(TP-BE): from 8.0 (BE-BE): from 8.0	S 24 H	S 24 HB 0,2-0,6	1412.016
0.3 - 1.3	(TP-BE): from 4.0 (BE-BE): from 5.0	S 24 H	S 24 HB 0,3-1,3	1412.012
0.4 - 2	(TP-BE): from 3.0 (BE-BE): from 3.0	S 24 H	S 24 HB 0,4-2	1412.011
0.5 - 4	(TP-BE): from 2.0 (BE-BE): from 2.0	S 24 H	S 24 HB 0,5-4	1412.010
Element diameter 40 mm, typical bandwidth 100 %, female connector: Lemo 1				
0.1 - 0.3	(TP-BE): from 15.0	S 40	S 40 HB 0,1-0,3	1408.003
0.2 - 0.6	(TP-BE): from 8.0 (BE-BE): from 9.0	S 40	S 40 HB 0,2-0,6	1408.002
0.3 - 1	(TP-BE): from 6.0 (BE-BE): from 6.0	S 40	S 40 HB 0,3-1	1408.001

Straight Beam Probes TR Probes

TR probes

- increased near surface resolution
- maximum sensitivity at focus distance
- reduced scattering echoes
- typical application: near surface flaw detection, determination of residual wall thickness



Straight Beam Probes TR Probes

Scale 1 : 1

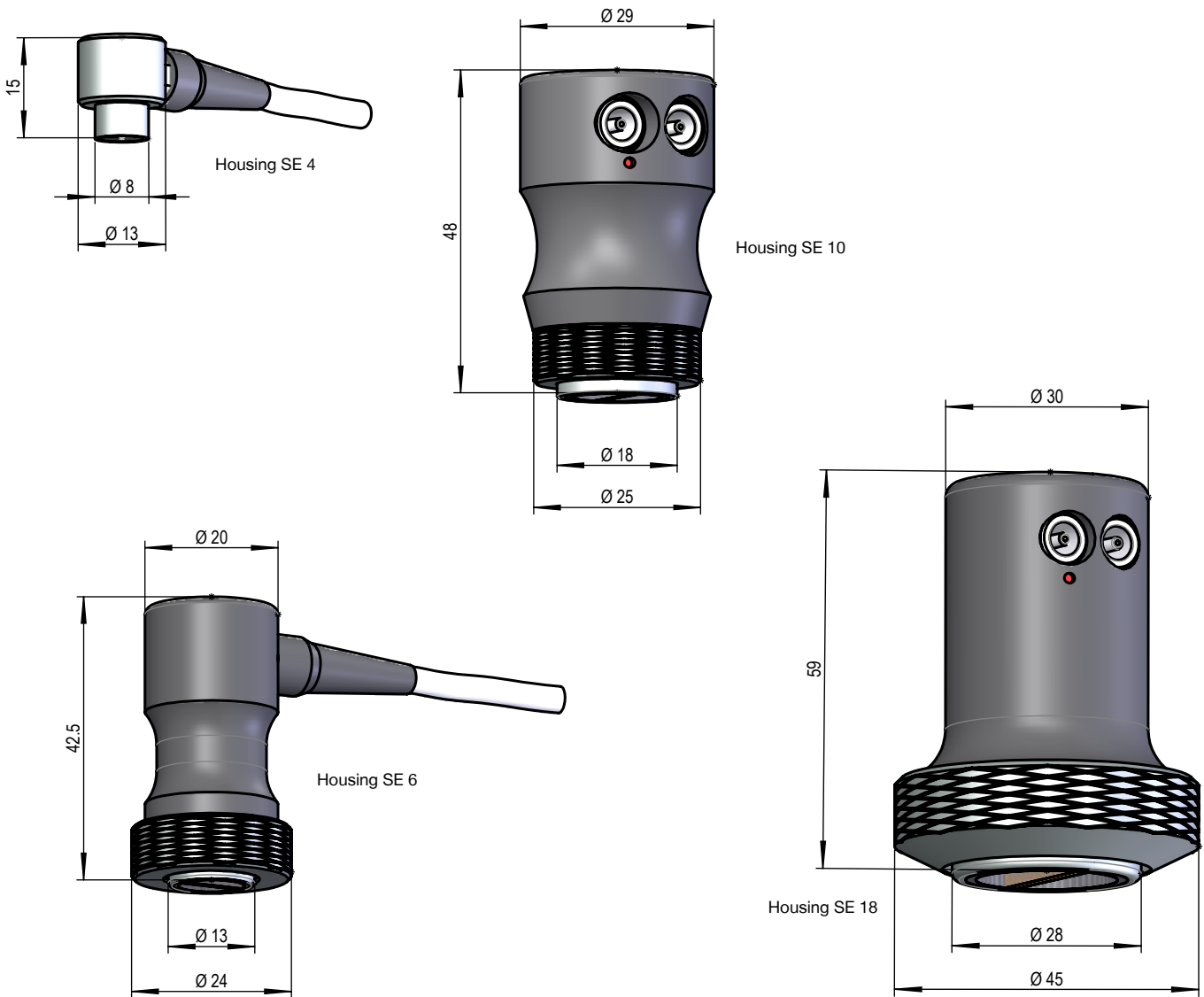

Focus distance* [mm]	Element dimensions [mm]	Frequency [MHz]	Housing	Part code	Order no.	Note
4	4 x 2	6	SE 4	SE 4.2/4 P 6	1464.001	1.5 m cable, 2x Lemo 1
4	4 x 2	10	SE 4	SE 4.2/4 PB 10	1464.101	1.5 m cable, 2x Lemo 1
5	$\varnothing 6$	4	SE 6	SE 6/5 PB 4 C	1464.165	1.5 m cable, 2x Lemo 1
6	$\varnothing 10$	4	SE 10	SE 10/6 PB 4 C	1462.106	2x Lemo 00 socket
6	$\varnothing 10$	6	SE 10	SE 10/6 PB 6 C	1462.206	2x Lemo 00 socket
10	$\varnothing 10$	2	SE 10	SE 10/10 PB 2 C	1462.044	2x Lemo 00 socket
14	$\varnothing 10$	4	SE 10	SE 10/14 PB 4 C	1462.144	2x Lemo 00 socket
25	$\varnothing 18$	2	SE 18	SE 18/25 PB 2	1463.225	2x Lemo 00 socket
25	$\varnothing 18$	4	SE 18	SE 18/25 PB 4	1463.425	2x Lemo 00 socket
40	$\varnothing 18$	4	SE 18	SE 18/40 PB 4	1463.440	2x Lemo 00 socket

* in steel

Straight Beam Probes

TR Probes for Wall Thickness Gauges ECHOMETER 1076/1077



Scale 1 : 1

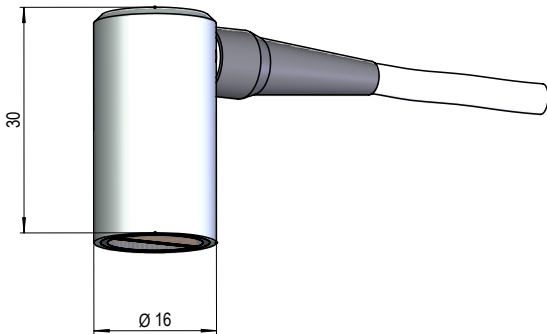

Housing DSE 10

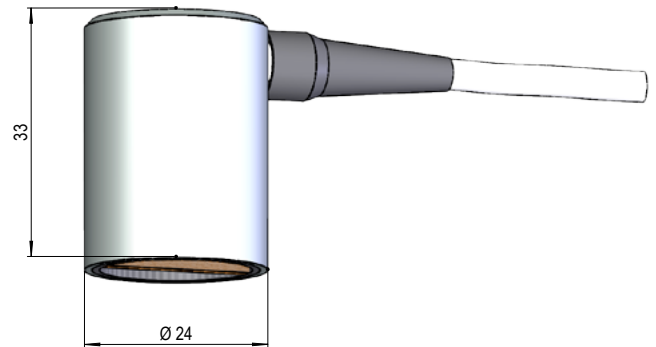

Housing DSE 18

Focus distance* [mm]	Element dimensions [mm]	Frequency [MHz]	Housing	Part code	Order no.	Note
4	4 x 2	10	SE 4	DSE 4.2/4 PB 10	1465.671	1 m cable, 2x Lemo 00
6	10 x 4	4	DSE 10	DSE 10.4/6 PB 4	1465.762	1 m cable, 2x Lemo 00
15	8 x 3	5	DSE 10	DSE 8.3/15 PB 5 C	1465.771	1 m cable, 2x Lemo 00, only for 1076 TC and 1077
15	8 x 3	5	DSE 10	DSE 8.3/15 PB 5 HT	1465.772	1 m cable, 2x Lemo 00, only for 1076 TC and 1077, operating range up to 150 °C
25	Ø 18	2	DSE 18	DSE 18/25 PB 2	1465.361	1 m cable, 2x Lemo 00

* in steel

Angle Beam Probes Transversal Waves



Angle beam probes

- appropriate for DGS
- Typical application: testing of welds, forgings, castings, etc.

Angle Beam Probes Transversal Waves

Scale 2 : 1

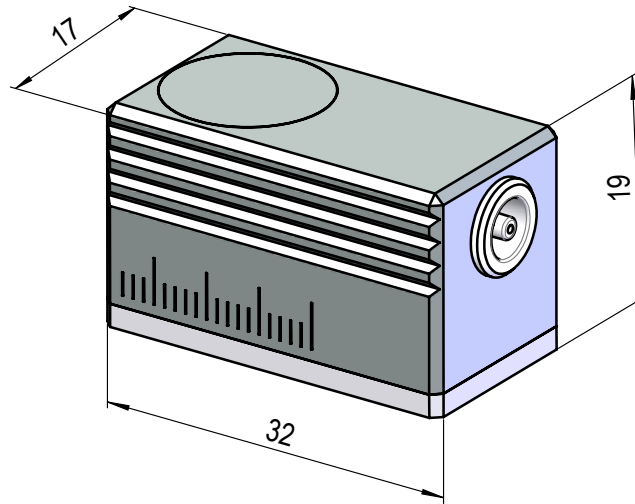

Housing WK

Beam angle* [°]	Frequency [MHz]	Part code	Order no.
small size design: element 9 mm by 8 mm, female connector: Lemo 00 (alternative: output on top), housing: WK			
35	2	WK 35 PB 2	1441.001
35	2	WK 35 PB 2C	1441.101
35	4	WK 35 PB 4	1441.011
45	2	WK 45 PB 2	1441.002
45	2	WK 45 PB 2 C	1441.102
45	4	WK 45 PB 4	1441.012
60	2	WK 60 PB 2	1441.003
60	2	WK 60 PB 2 C	1441.103
60	4	WK 60 PB 4	1441.013
70	2	WK 70 PB 2	1441.004
70	2	WK 70 PB 2 C	1441.104
70	4	WK 70 PB 4	1441.014
80	2	WK 80 PB 2	1441.005
80	4	WK 80 PB 4	1441.015
90	2	WK 90 PB 2	1441.006
90	4	WK 90 PB 4	1441.016

* beam angle of transversal wave in steel

Angle Beam Probes Transversal Waves

Beam angle* [°]	Frequency [MHz]	Part code	Order no.
medium size design: element 14 mm by 14 mm, female connector: Lemo 00 (alternative: output on top), housing: SWM			
35	2	SWM 35 PB 2 C	1498.183
45	2	SWM 45 PB 2 C	1498.081
45	5	SWM 45 PB 5 C	1498.125
60	2	SWM 60 PB 2 C	1498.116
60	5	SWM 60 PB 5 C	1498.126
70	2	SWM 70 PB 2 C	1498.117
70	5	SWM 70 PB 5 C	1498.127

Scale 1 : 1.5

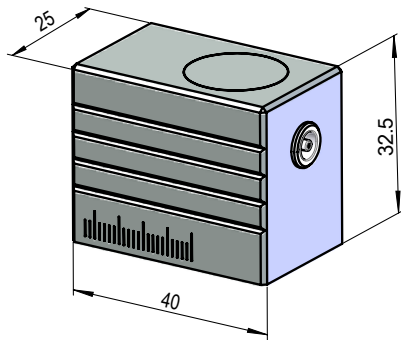

Housing SWM

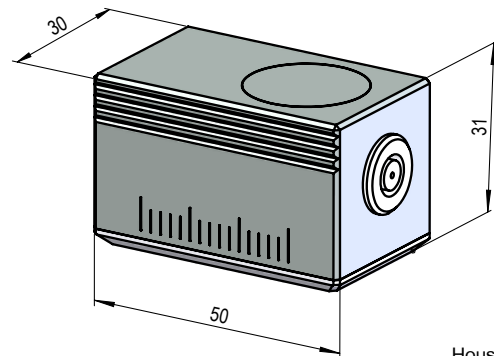

Housing WG

Beam angle* [°]	Frequency [MHz]	Part code	Order no.
large size design: element 24 mm by 16 mm, female connector: Lemo 1, housing: WG			
35	1	WG 35 PB 1 C	1416.135
35	2	WG 35 PB 2	1416.235
35	4	WG 35 PB 4	1416.435
45	1	WG 45 PB 1 C	1416.145
45	2	WG 45 PB 2	1416.245
45	4	WG 45 PB 4	1416.445
60	1	WG 60 PB 1 C	1416.160
60	2	WG 60 PB 2	1416.260
60	4	WG 60 PB 4	1416.460
70	1	WG 70 PB 1 C	1416.170
70	2	WG 70 PB 2	1416.270
70	4	WG 70 PB 4	1416.470

* beam angle of transversal wave in steel

Angle Beam Probes with Wedges



Example: S 6 WB 5 WM with angle beam wedge WM 60

Frequency [MHz]	Part code	Order no.
Element diameter 6 mm, Female connector: Microdot, housing: S 6		
2.25	S 6 WB 2.25 WM	1457.001
5	S 6 WB 5 WM	1457.002
10	S 6 WB 10 WM	1457.003

Angle beam wedges WM			
Beam angle* [°]	Part code	Order no.	Dimensions L / B / H1 / H2
45	WM 45	1818.001	21 / 12.5 / 11 / 19
60	WM 60	1818.002	25 / 12.5 / 13.5 / 20
70	WM 70	1818.003	26.5 / 12.5 / 13.5 / 21
90**	WM 90	1818.004	25 / 12.5 / 15 / 17

** surface wave

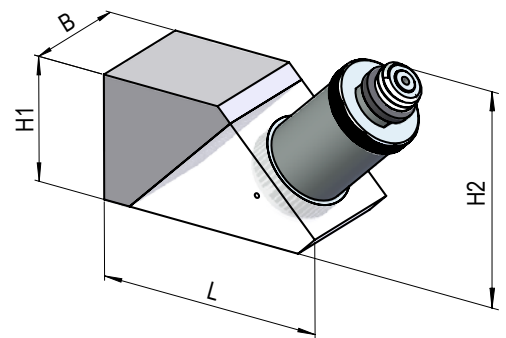

Housing S 6 with wedge



* beam angle of transversal wave in steel

Angle Beam Probes Longitudinal Waves

Scale 1 : 1

Housing S 12 W

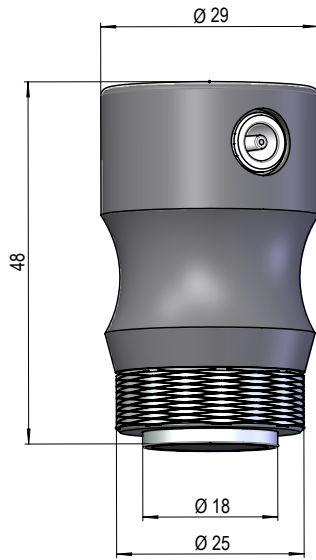

Housing SWM

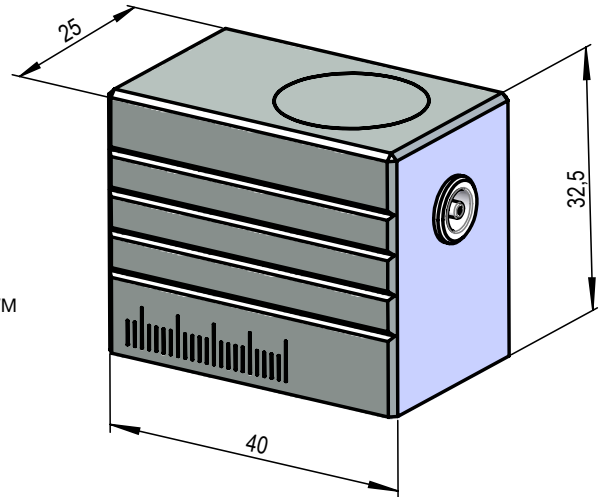

Housing S 24 W

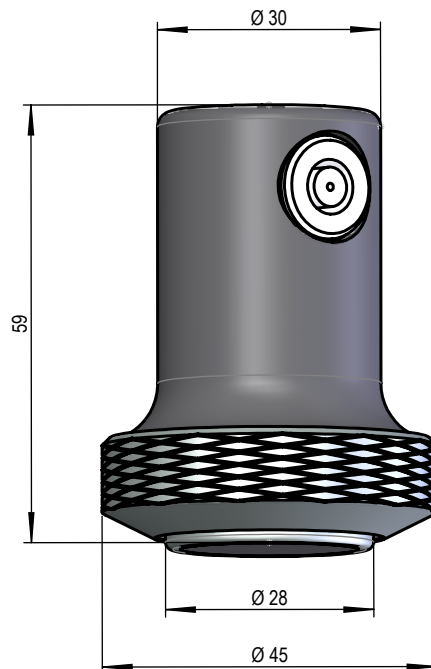

Angle Beam Probes Longitudinal Waves

Beam angle* [°]	Frequency [MHz]	Part code	Order no.
Element diameter 10 mm, female connector: Lemo 00, housing: S 12 W			
7	2	SWL 10/7 P 2	1498.248
7	4	SWL 10/7 P 4	1498.155
14	2	SWL 10/14 P 2	1498.249
14	4	SWL 10/14 P 4	1498.156
21	2	SWL 10/21 P 2	1498.250
21	4	SWL 10/21 P 4	1498.157
28	2	SWL 10/28 P 2	1498.251
28	4	SWL 10/28 P 4	1498.158
Element diameter 12 mm, female connector: Lemo 00, housing: SWM			
45	2	SWL 12/45 PB 2 C	1498.135
45	4	WL 12/45 PB 4 C	1456.001
60	2	SWL 12/60 PB 2 C	1498.136
60	4	WL 12/60 PB 4 C	1456.002
70	2	SWL 12/70 PB 2 C	1498.137
70	4	WL 12/70 PB 4 C	1456.003
Element diameter 24 mm, female connector: Lemo 1, housing: S 24 W			
7	2	SWL 24/7 P 2	1498.100
7	4	SWL 24/7 P 4	1498.148
14	2	SWL 24/14 P 2	1498.101
14	4	SWL 24/14 P 4	1498.149
21	2	SWL 24/21 P 2	1498.102
21	4	SWL 24/21 P 4	1498.150
28	2	SWL 24/28 P 2	1498.103
28	4	SWL 24/28 P 4	1498.151

* beam angle of longitudinal wave in steel

Angle Beam Probes Angle Beam TR Probes

Scale 1.5 : 1

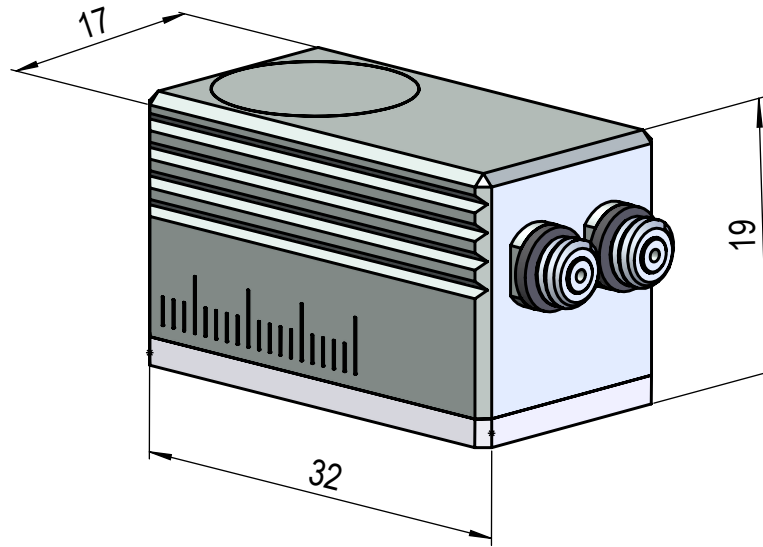

Housing SE-WK

Beam angle* [°]	Element- dimensions [mm]	Part code	Order no.
Transversal waves, frequency: $f = 4$ MHz (2 MHz on request), female connector: Microdot, housing: SE-WK			
45	5 x 6	WSE 5.6/45 PB 4	1461.311
60	5 x 6	WSE 5.6/60 PB 4	1461.312
70	5 x 6	WSE 5.6/70 PB 4	1461.313
Longitudinal waves, frequency: $f = 4$ MHz (2 MHz on request), female connector: Microdot, housing: SE-WK			
45	5 x 8	WSEL 5.8/45 PB 4	1461.401
60	5 x 8	WSEL 5.8/60 PB 4	1461.402
70	5 x 8	WSEL 5.8/70 PB 4	1461.403

* in steel

Probes

Technical Meaning of the Part Code

ECHOGRAPH probes can be identified by their order number or part code. The technical meaning of the alphanumeric part code is described below:

Type	Element Dimensions	Specifications	Nominal Frequency	Additional Information
S = straight beam probe (DS = fingertip design)	with round elements: n or n/... element diameter in mm	H = hard wear plate W = protective foil P = plastics delay line B = extended or extreme band- width (with frequency limits)	Frequency in MHz, frequency limits are given as upper and lower cut-off frequency (-6 dB)	C = composite element WM = for angle beam wedges HT = for high temperatures
SE = TR-probe (transmitter/ receiver) (DSE = fingertip design)	with rectangular elements: l.b or l.b/... element dimensions with length (l) and width (b) in mm			
WK = angle beam probe (small) SWM = angle beam probe (med) WG = angle beam probe (large)	with angle probes: α or .../ α beam angle in degrees			
WL and SWL = angle beam probe (longitudinal waves)	with focused probes (except SWL): .../z focus distance in mm			
WSE = TR angle beam probe				

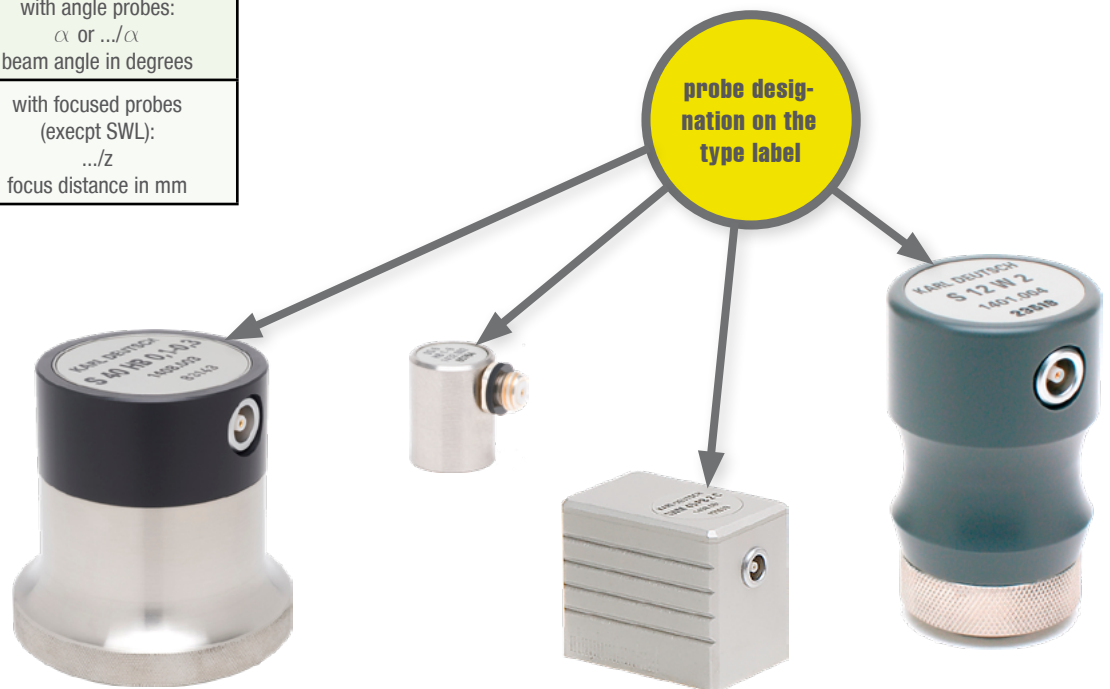

Examples

S 10 W 2 C

Straight beam probe, element diameter 10 mm, protective foil, nominal frequency 2 MHz, composite element

DS 12 HB 2-7

Straight beam probe in fingertip design, element diameter 12 mm, hard wear plate, extreme bandwidth 2-7 MHz

SWL 24/21 PB 2

Special angle beam longitudinal wave probe, element diameter 24 mm, beam angle 21°, plastic delay line, extended bandwidth 2 MHz

SWM 60 PB 5 C

Special angle beam probe in medium size housing, beam angle 60°, plastic delay line, extended bandwidth 5 MHz, composite element

SE 4.2/4 PB 10

TR probe, element length 4 mm, element width 2 mm, focal distance 4 mm, plastic delay line, extended bandwidth 10 MHz

Special Probes

A Selection from our Range of Products

We produce probes for your application. Please talk to us.

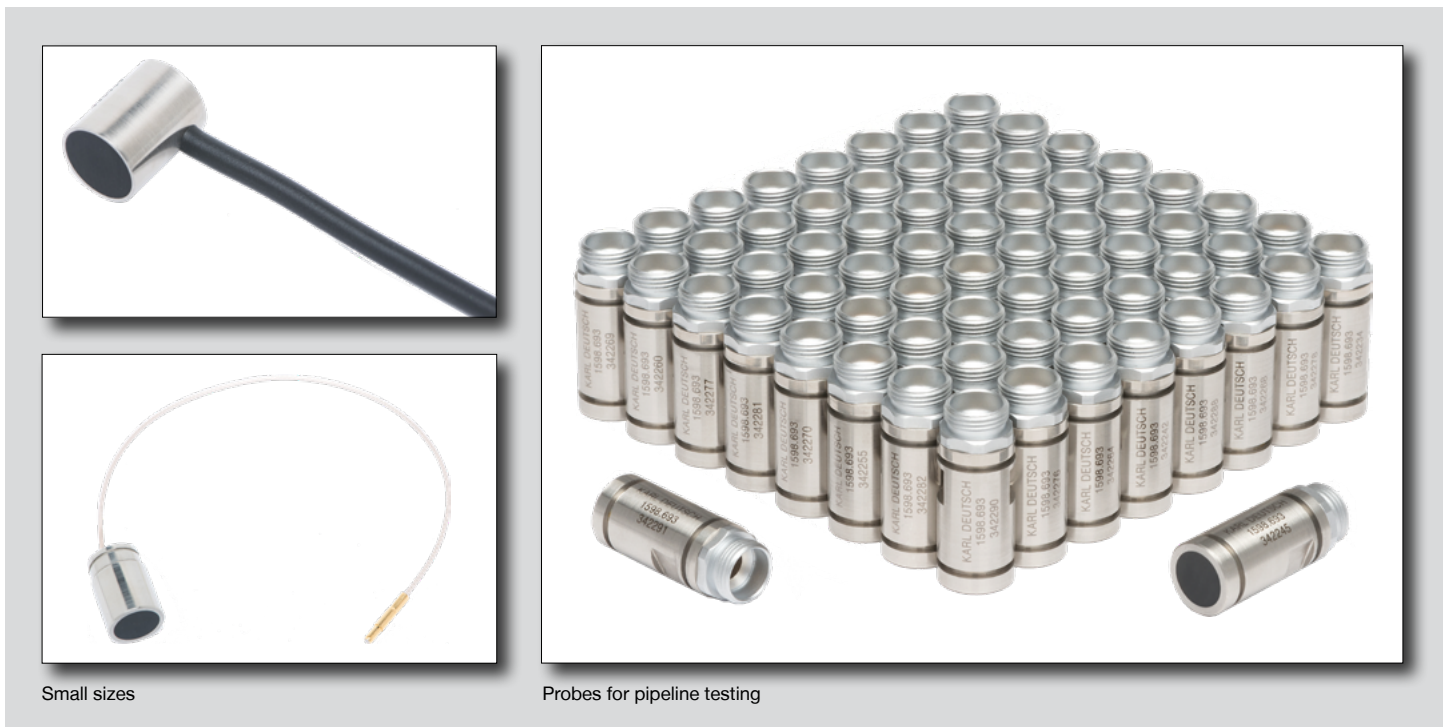
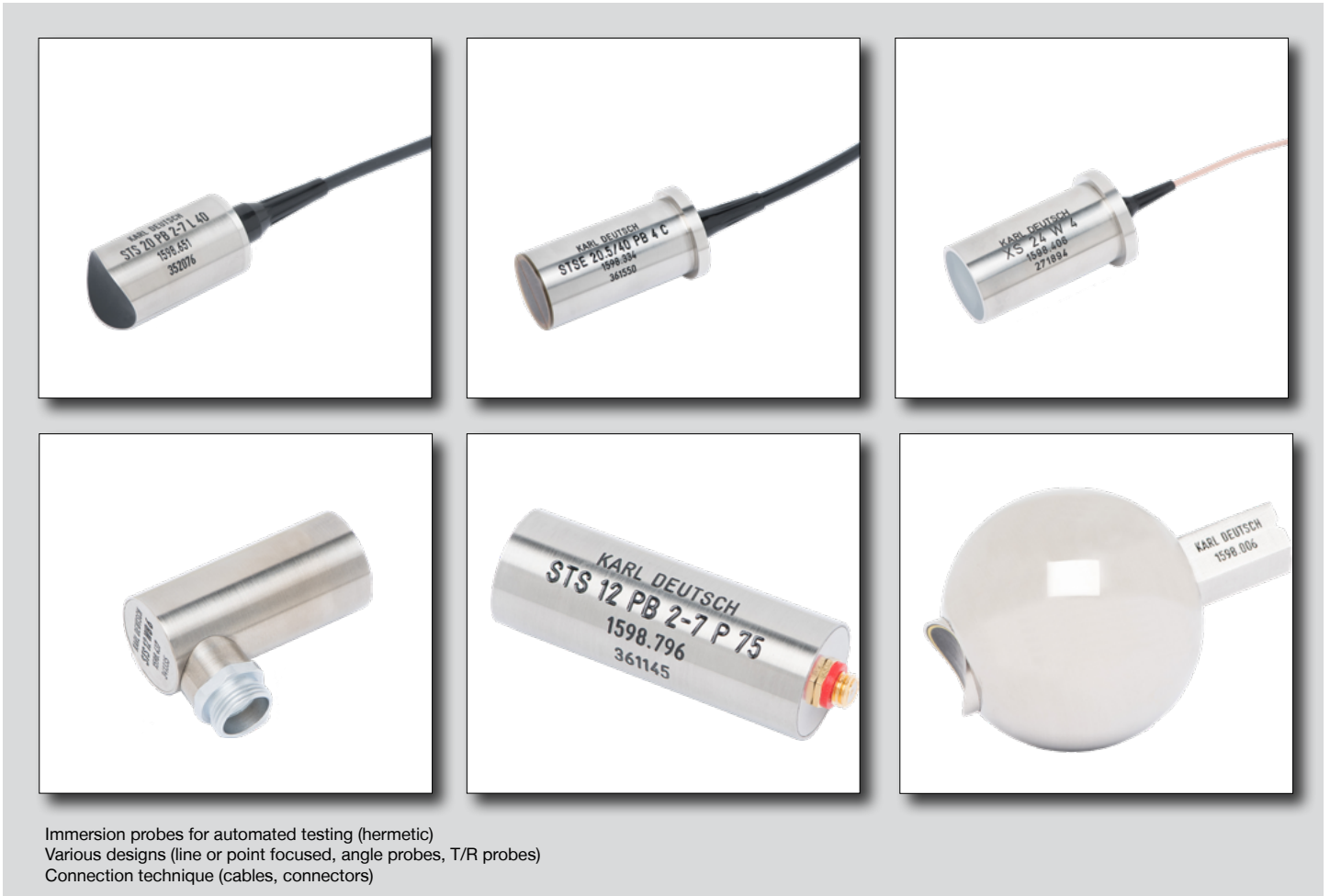



Multielement probes



Phased Arrays

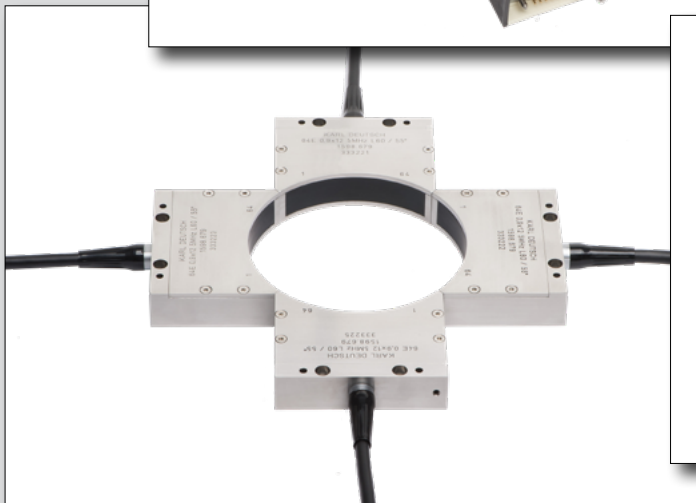

Phased array probes for manual and automated testing (more information to be found in leaflet "P 14 Phased Array")

Probes

Guidelines for the Choice of Ultrasonic Probes

What has to be considered when selecting ultrasonic probes?

The great variety of ultrasonic probes for NDT applications may initially appear confusing. However, the following notes will facilitate the selection. It is recommended to proceed in the order shown below.

1. Probe type (straight beam or angle beam; single element or dual element)
2. Nominal frequency and bandwidth
3. Element dimensions
4. Wear plate, protective foil or delay line

1. Probe type

Straight beam or angle beam?

- **Select** the **direction of sound propagation** so the flaws are hit perpendicularly in order to obtain large echo indications, if possible.
- **Use control echos** (for example back-wall echos) from the end of the test area to monitor the coupling of the probe and the occurrence of sound-absorbing or scattering points in the material. This increases the test reliability.
- **Avoid** any **geometric echos** caused by sound deflections at hidden, round or oblique edges in the material under test.

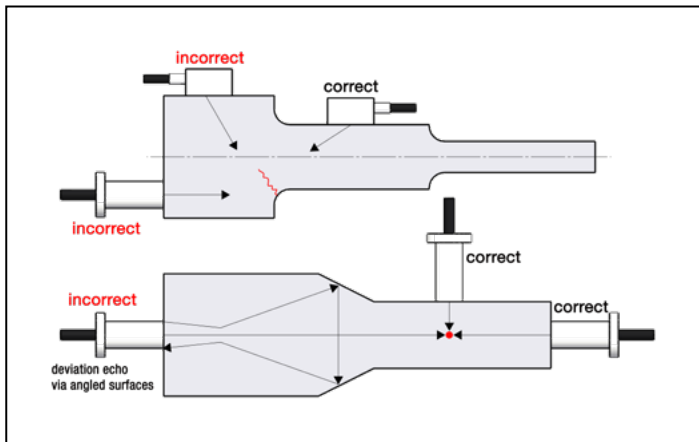

Example for correct and incorrect direction of insonification

When using TR probes it should be noted that ...

- flaws can not be detected too close to the surface. They have to be outside the “dead zone” which extends from a depth of 0 to approx. 1-3 mm below the surface depending on the type of the TR probe
- the improvement in the near surface resolution (defect detection close to the surface) comes with a lower sensitivity at greater depths
- depending on the surface roughness and curvature of the material under test, an overcoupling echo may occur, which will make the evaluation more difficult
- TR probes should be selected in such a way that the position of the flaws to be detected coincides, as far as possible, with its depth of focus (point of highest sensitivity).

Single or dual element?

Ultrasonic **single element** probes fulfill most of the test tasks in practice. Furthermore they are required in through-transmission mode or when (in rare cases) tandem or delta technique is applied.

Dual element or TR probes (one transmitter and one receiver) are recommended when surface near resolution (for example, detection of small defects in small depth) has to be improved and/or the sensitivity has to be “focused” to a certain depth.

Probes

Guidelines for the Choice of Ultrasonic Probes

2. Nominal frequency and bandwidth

Frequency spectrum and pulse shape of an ultrasonic impulse are linked:

Impulses with **short pulse duration** have a high bandwidth in the frequency spectrum, which means they simultaneously emit a multitude of different frequencies. The superposition results in a short pulse length with regularly only one half cycle.

Impulses with a **longer pulse duration** show several oscillation cycles. They have a pronounced characteristic frequency and a narrow frequency spectrum.

Shortcuts used in the text:

- λ = wavelength
- c = sound velocity
- f = frequency
- t = pulse duration
- ϑ = opening angle
- D_{eff} = effective element diameter

Indications for high frequency transducers:

- With increasing frequency the wavelength decreases since

$$\lambda = \frac{c}{f}$$

Therefore, the minimum size of detectable reflectors is reduced.

- Due to the relation

$$t = \frac{1}{f}$$

the duration of one or several oscillation cycles decreases in length for higher frequencies. A higher frequency results in a better near surface resolution and an improved axial resolution of reflectors, which lie closely behind each other.

Indications for low frequency transducers are

- highly scattering materials (for example austenitic materials, cast iron with lamellar graphite, non-ferrous casting, etc.)
- highly absorbing materials, e.g. many plastics
- flat, non-perpendicularly orientated flaws. Such reflectors show the same characteristics as an equally-sized transmitter at that position. Since

$$\sin \vartheta_{-20\text{ dB}} = 1.09 \cdot \frac{c}{f \cdot D_{eff}}$$

the beam divergence of the transmitted and reflected beam increases for lower frequencies. Therefore the probability of detection of the flaws is improved.

Rule of thumb:

- High frequencies for short sound paths in materials with low absorption and / or scattering
- Low frequencies for long sound paths in materials with strong absorption and / or scattering

Note:

A material is generally considered to be testable if the echo of a reference reflector (eg. back wall, side drilled hole or similar) is sufficiently clear (6 - 10 dB) above the noise level (structural noise, electronic noise). If there is no back wall echo due to excessive sound attenuation, it is often possible to use the through transmission method (half sound path).

ECHOGRAPH probes are provided in three different frequency bandwidths which can be selected according to the following criteria:

Small bandwidth

Longer impulses: Since a pronounced test frequency is present, all frequency-dependent data of the sound beam (eg. nearfield length, divergence angle, wavelength, etc.) can be specified. These probes are qualified for the DGS method or similar procedures. The test frequency can be regarded as constant, irrespectively of the material. However, because of the longer lasting impulses, certain limitations have to be made regarding the axial resolution.

Extended bandwidth

Narrow impulses: These probes provide a good compromise between the requirements for high resolution and a defined test frequency. While offering improved resolution, no significant frequency shift occurs in materials with low scattering and absorption. Therefore, specifications of frequency dependent data and applications of test methods are still possible.

Extremely large bandwidth

Narrowest impulses: Probes with these characteristics offer an optimum in resolution and signal-to-noise ratio (structural noise). They are employed with great success in testing highly sound scattering materials (e.g. austenite, casting). Another field of application is the generation of very short impulses for precise wall thickness measurement.

Probes

Guidelines for the Choice of Ultrasonic Probes

3. Element Dimensions

In addition to the frequency and bandwidth, the transducer size primarily determines sound beam parameters such as near field length and divergence angle in the far field. For modifications of the transducer dimensions the changes described below should be considered:

Near field

At the end of the near field (= near field length), the highest test sensitivity is observed because of the maximum constriction of the sound beam. The near field length is calculated as:

$$N = \frac{D_{eff}^2 \cdot f}{4 \cdot c}$$

for circular shaped elements and

$$N_{\blacksquare} = k_{\blacksquare} \cdot \frac{a^2 \cdot f}{4 \cdot c}$$

for rectangular shaped elements. The constant k_{\blacksquare} depends on the ratio of the edge lengths a/b . k_{\blacksquare} amounts to 1.37 for $a/b = 1$, for $a/b > 2$ it amounts to 1.

As a result of interferences in the near field region, sound pressure distribution respectively transducer sensitivity vary locally. Thus, lateral reflector detection and quantitative description are only possible from a distance of approx. 0.7-times the near field length.

Far field

With increasing distance from the transducer and lateral shift from the sound beam axis, the test sensitivity steadily decreases. Lateral flaw detection as well as quantitative description are possible. The opening angle of the sound beam with pulse-echo-mode is calculated as follows:

$$\sin \vartheta_{-20\text{ dB}} = 0.87 \cdot \frac{c}{f \cdot D_{eff}}$$

with 20 dB threshold, and

$$\sin \vartheta_{-6\text{ dB}} = 0.51 \cdot \frac{c}{f \cdot D_{eff}}$$

with 6 dB threshold for circular shaped elements. Divergence angles and near field lengths vary for rectangular shaped elements according to short and long side lengths.

Conclusions

- Small elements provide short near field lengths and large divergence angles in the far field. They should be used therefore in the first place for the detection of flaws at low distances.
- Large transducers have large near field lengths and low opening angles (strong constriction). They are recommended for the detection of reflectors at a greater distance.
- For an optimized detection sensitivity, the element diameter should be chosen in such a way that the near field length coincides approximately with the distance of the flaw.
- If quantitative evaluations (e.g. DGS or reference line) are carried out, the element size has to be chosen considering the near field length is not greater than approx. 1.4 times the distance of the nearest flaw.

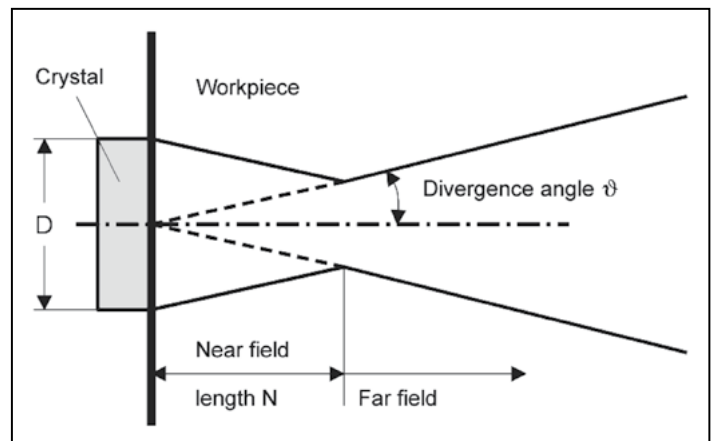

Shortcuts used in the text:

- N = near field length
- D_{eff} = effective diameter
(only a few % less than the real element diameter)
- f = frequency
- c = sound velocity
- a = long side of rectangle
- b = short side of rectangle
- ϑ = opening angle

Probes

Guidelines for the Choice of Ultrasonic Probes

4. Wear Plate, Protective Foil or Delay Line

The probe face is equipped with an in general some tenths of a millimeter thick protective layer or a delay line. Apart from protection of the transducer against mechanical damage, they are used for acoustic matching. This comprises a good resolution and an optimum of sound transmission between the involved materials, that are transducer material - protective layer (protective cap, if applicable) - coupling liquid – material under test. The following characteristic features apply:

1. Straight beam probes

Hard protective wear plate made of ceramics or carbide metal, e.g. tungsten carbide or titanium carbide. Extremely wear-resistant, protected with a steel ring. Main applications: For smooth and / or sharp-edged surfaces as well as for broadband probes.

Soft protective foil made of non-slip material for an optimum coupling on rough surfaces. To prohibit excessive wear, the probes never should be used without cap or foil. The generation of very short impulses or broadened frequency spectrum is usually not possible for matching reasons.

Delay Line made of plastics or ceramics: For high-resolution wall thickness measurements or as a heat protection for hot surface measurements. Fixed to the probe housing by using the foil holding ring.

2. Angle beam probes

As wedge material of the angle beam probes in most cases PMMA (e.g. Plexiglas®, Perspex®) is applied, which is a very good compromise between acoustic matching and absorption. In case of wear, a PMMA plate can be glued on the probe face as a wear plate. However, it is recommended to use clamp-on PMMA attachments, which can be customized to all possible surface shapes and are easily exchangeable if worn.

3. TR probes

Solid delay lines made of abrasion resistant plastics such as PMMA or (e.g. for high temperature testing) made of heat-resistant plastics or ceramics material.

Cables

Part code	Recommended for probe type	Order no.
Probe cable (1 m), Microdot / Lemo 00	DS ... / S 6 ...	1618.010
Probe cable (2 m), Microdot / Lemo 00	DS ... / S 6 ...	1618.020
Probe cable (2 m), Microdot / Lemo 1	DS ... / S 6 ...	1615.200
Probe cable (1 m), Lemo 00 / Lemo 00	S 10 ... / S 12 ...	1616.010
Probe cable (2 m), Lemo 00 / Lemo 00	S 10 ... / S 12 ...	1616.020
Probe cable (1 m), Lemo 00 / Lemo 1	S 10 ... / S 12 ...	1614.010
Probe cable (2 m), Lemo 00 / Lemo 1	S 10 ... / S 12 ...	1614.020
Probe cable (5 m), Lemo 00 / Lemo 1	S 10 ... / S 12 ...	1614.050
Probe cable (2 m), Lemo 1 / Lemo 1	S 24 ... / S 40 ...	1613.020
Probe cable (5 m), Lemo 1 / Lemo 1	S 24 ... / S 40 ...	1613.050
Probe twin cable (2 m), Microdot / Lemo 1	WSE ... / WSEL ...	1615.202
Probe twin cable (2 m), Lemo 00 / Lemo 1	SE 10 ... / SE 18 ...	1614.022
Probe twin cable (5 m), Lemo 00 / Lemo 1	SE 10 ... / SE 18 ...	1614.052
Probe twin cable (1 m), Lemo 00 / Lemo 00	SE 10 ... / SE 18 ...	1698.044
Probe twin cable (2 m), Lemo 00 / Lemo 00	SE 10 ... / SE 18 ...	1698.077



Protective Foils, Retaining Rings, Handling Sleeves

Part code	Recommended for probe type	Order no.
Pack of 10 protective foils	S 10 W ...	1930.007
Retaining ring for foils	S 10 W ...	1931.005
Pack of 10 protective foils	S 12 W ... / SE 10 ...	1930.006
Retaining ring for foils	S 12 W ... / SE 10 ...	1931.002
Pack of 10 protective foils	S 24 W ... / SE 18 ...	1930.008
Retaining ring for foils	S 24 W ... / SE 18 ...	1931.008
Pack of 10 protective foils	S 40 W ...	1930.003
Retaining ring for foils	S 40 W ...	1931.003
Handling sleeves	DSE 4.2 ... / SE 4.2 ...	1934.251
Pack of 10 protective foils	DSE 4.2 ... / SE 4.2 ...	1930.005
Handling sleeves	DSE 10.4 ... / DSE 8.3 ...	1934.151
Pack of 10 protective foils	DSE 10.4 ... / DSE 8.3 ...	1930.006
Handling sleeves	DSE 18 ...	1934.201
Pack of 10 protective foils	DSE 18 ...	1930.004

Delay Lines, Replacement Wear Plates, Angle Beam Wedges

Part code	Recommended for probe type	Order no.
Delay line (for housing: DS 6 P / DS 6 PB), 10 mm long	DS 6 PB 4-14	1932.001
Delay line (for housing: DS 6 P / DS 6 PB), 6 mm	DS 6 PB 4-14	1932.003
High temperature delay line (for housing: DS 6 P / DS 6 PB), 10 mm	DS 6 PB 4-14	1932.004
Retaining ring (for housing: DS 6 P)	DS 6 PB 4-14	1933.001
Retaining ring (for housing: DS 6 PB)	DS 6 PB 4-14 / S 6 WB ...	1898.011
Delay line (for housing: S 12 PB), 10 mm long	S 12 PB ...	1932.005
Delay line (for housing: S 12 PB), 25 mm long	S 12 PB ...	1932.006
High temperature delay line (for housing: S 12 PB), 25 mm long	S 12 PB ...	1932.007
Retaining ring (for housing: S 12 PB)	S 12 PB ...	1933.010
Replacement wear plates (10 pcs)	WK ...	1935.101
Perspex shoe	WK ...	1820.171
Clamping spring	WK ...	1822.170
Replacement wear plates (10 pcs)	SWM ...	1935.301
Replacement wear plates (10 pcs)	WG ...	1935.202
Perspex shoe	WG ...	1819.001
Clamping spring	WG ...	1821.001
Angle beam wedge 45° (screw mountable)	S 6 WB ...	1818.001
Angle beam wedge 60° (screw mountable)	S 6 WB ...	1818.002
Angle beam wedge 70° (screw mountable)	S 6 WB ...	1818.003
Angle beam wedge 90° (screw mountable)	S 6 WB ...	1818.004

Cable Extensions

Plug type	Required cable coupler	Order no.
Lemo 1*		1913.001
BNC**		1912.001
Lemo 00***		1914.001





cable required for extension in each case (length shown in parenthesis):

* order no. 1613.020 (2 m) / 1613.050 (5 m)

** order no. 1610.200 (2 m) / 1610.500 (5 m)













*** order no. 1616.010 (1 m) / 1616.020 (2 m)

Adapters















Connection type	Adapter	Order no.
BNC plug <> Lemo 1 socket		1696.001
Lemo 1 plug <> BNC socket		1695.001
Adapter UHF plug <> BNC socket		1697.0011
Lemo 00 plug <> BNC socket		1691.001
BNC plug <> Lemo 00 socket		1698.109

Probe Cables for Portables and Systems

Probe Cables for Connection to Portable ECHOGRAPH Instruments

Probe socket	Plug probe side	Cable length	Order no.	Plug instrument side	Instrument socket
	 Microdot	2 m 2 x 2 m Probe twin cable for TR-probe	1615.200 1615.202	 Lemo 1	
	 Lemo 00	1 m 2 m 5 m 2 x 2 m Probe twin cable for TR probe	1614.010 1614.020 1614.050 1614.022		
	 Lemo 1	2 m 5 m	1613.020 1613.050		
	 Lemo 0 hermetic	2 m	1611.021		
	 Lemo 1 hermetic	2 m	1611.022		

Probe Cables for Connection to ECHOGRAPH Test Systems

Probe socket	Plug probe side	Cable length	Order no.	Plug system electronics	System socket
	 FVN pressure tight	2,5 m	1611.026	 BNC	
	 Microdot	2 m	1619.020		
	 Lemo 00	2 m	1617.020		
	 Lemo 1	2 m 2 m 5 m	1612.020 1612.200 1612.500		
	 Lemo 0 hermetic	2 m	1611.020		
	 Lemo 1 hermetic	2 m	1611.023		

Company Location Wuppertal and Worldwide Presence



Works 1 at Otto-Hausmann-Ring 101

Management, Administration, Development, Production of Portable Instruments, Sensors and Test Media



Works 2 at Otto-Hausmann-Ring 201

Development, Construction and Production of Ultrasonic, Magnetic Particle and Penetrant Testing Systems

KARL DEUTSCH worldwide.

In addition to our company location in Wuppertal we support branch offices and agencies in Europe, Asia, America, Africa and Australia. Due to our worldwide presence we obtain an export rate above 50%. Thus we guarantee to our customers technical and innovative support in many countries and to meet customers requests directly.

Argentina	France	Columbia	Portugal	Sri Lanka
Australia	Greece	Korea	Romania	South Africa
Egypt	Great Britain	Malaysia	Russia	Taiwan
Belgium	India	Mexico	Saudi Arabia	Thailand
Brazil	Indonesia	Netherlands	Sweden	Czech Republic
Bulgaria	Iran	Austria	Switzerland	Turkey
China	Israel	Peru	Singapore	Hungary
Denmark	Italy	Philippines	Slovakia	USA
Finland	Japan	Poland	Spain	Vietnam

An overview of all agencies worldwide can be found on www.karldeutsch.de ⇒ English ⇒ Agencies Worldwide

KARL DEUTSCH Prüf- und Messgeraetebau GmbH + Co KG
Otto-Hausmann-Ring 101 · 42115 Wuppertal · Germany
Phone +49 202 7192 0
info@karldeutsch.de · www.karldeutsch.de

DIN EN ISO
9001
certified

KARL DEUTSCH